

## ***Locating Hidden Hazards in Electrical Wiring***

Paul K. Kuhn, Ph.D.

*(LiveWire Test Labs, Inc.)*

Cynthia Furse, Ph.D.

*(Electrical and Computer Engineering, University of Utah and LiveWire Test Labs, Inc.)*

Paul Smith, Ph.D.

*(LiveWire Test Labs, Inc.)*

### *Abstract*

Hazardous electrical wiring has been identified as an area of critical national and international concern. Faulty and improperly installed electrical wiring is a leading cause of fires in homes and commercial buildings. Wiring is also responsible for numerous problems in consumer product safety, vehicular safety/reliability, safety of nuclear facilities, reliability of power distribution systems, reliability of communication systems, and others. Faults in aircraft wiring have been implicated in a number of severe aircraft accidents including the Swiss Air-111, TWA-800, and UAL-811 flights as well as many flight delays.

Typically, wiring faults are hidden behind walls and panels and are generally hard to find. Locating intermittent faults is particularly difficult, as these faults are detectable only when active. To add to the problem, Arc-fault Circuit Breaker (AFCI) devices are just becoming routine in industry. Although AFCI devices reduce the risk of fire, they make it extremely difficult to find and repair a wiring fault after they trip, because so little damage has been done to the wiring. New technology is needed to locate these faults so they can be repaired.

The University of Utah and LiveWire Test Labs, Inc., in partnership, have been developing new methods for locating faults in electrical wiring. This technology can be used to detect problems in both live and "dead" wires. It can locate faults that last 1 millisecond or more. The faults may be located even if the wiring harnesses are hidden behind panels and require connection at only one end of the wire. With this technology, "hard" faults, intermittently-open circuits, and intermittently-short circuits (including drips of water bridging two conductors) can be detected and located. Lesser faults are more difficult to detect. Faults can typically be located to within +/-1 foot over 100 feet of wire, but the parameters of the system may be adjusted to increase or decrease the accuracy and total distances.

The technology is based on spread spectrum communication techniques, similar to what is used in cell phones. It can locate faults on live wires by adding less than 1 mW of power to the communication signal. This system can operate on active power or data lines without interfering with the active circuitry. On "dead" wires, this technology can operate with even less power than on the live systems.

### *Introduction*

In 2005, almost 400,000 fires occurred in homes and commercial buildings within the United States leading to over 3000 deaths and almost 14,000 injuries [2][3]. Using updated average statistics from the NFPA [4], about 65,000 of these fires were ignited by some sort of electrical fault. The data shows that these electrical faults contributed to the deaths of 240 civilians (non-firefighters), 890 injuries, and \$703 million in property damage. Wiring is also responsible for numerous problems in aircraft, consumer product safety, vehicular safety/reliability, safety of nuclear facilities, reliability of power distribution systems, reliability of communication systems, and others.

Since 1882, when the Edison Electric Company began the electrical transformation of the world with the electrical renovation of J. P. Morgan's home on Madison Avenue in New York, people have been struggling with wiring problems and the resultant fires [1]. While wiring types have changed many times since that early installation, some of the fundamental problems with wiring remain the same. After a

decade or two of use, wiring systems break down and arcs begin to occur. The causes to the wiring faults are numerous. A few examples include: improper installation, remodeling damage to the wires and/or insulation, degradation due to moisture, critters mistaking the wires to be a suitable snack, and simple the aging of the insulation. These problems extend not only to building structures alone, but to anything containing electrical system interconnects.

The University of Utah and LiveWire Test Labs are jointly developing test equipment to detect and locate faults in wiring systems. The products in development are initially targeting wiring faults in aircraft. Our strategy is to prove the technology in the aviation environment and expand it into applications such as building wiring, automobiles and other environments where fires can occur due to wiring failures. As the issues are similar, we hope to highlight some of our current efforts in this paper with a look to the future applications in residential and commercial buildings.

As today's military and commercial aircraft age, the many kilometers of wiring buried deep within their structures begin to crack and fray. Once thought to be rare and benign, such faults are found by the hundreds in a typical aircraft. Unlike obvious cracks in a wing or an engine, damaged wire is extremely difficult to detect, but the resulting arcing and electromagnetic emissions can be just as deadly: faulty wiring has been implicated in the downing of Swiss Air 111 near Nova Scotia in 1998 and of TWA 800 off New York's Long Island in 1996. Indeed, any densely wired system is vulnerable--the space shuttle, nuclear power plants, subways and railroads, large industrial machinery, homes and business buildings, communication and power distribution networks, and even the family car.

Investigations into some of the more notorious aircraft accidents have uncovered many issues common with most wiring systems. For example, inspections of a typical in flight entertainment system of an MD-11 aircraft (the Swiss Air 111 aircraft) shows wiring bundles secured by tight nylon tie-wraps close to sharp internal edges of the cabin and chaffing wire guides [5]. Age and vibration could easily compromise the insulation and become the source of electrical arcing.

Typically, a copper conductor (from 1 to 10 mm in diameter) is covered by a thin outer insulation (from 0.5 to 2 mm thick). Damaged insulation can expose the copper, giving rise to arcs, shorts, and electromagnetic emission and interference. As the wire ages, the insulation may become brittle and crack. Chafes appear as wires vibrate against each other, a tie-down, or any other hard surface.

Routine repairs can also be hard on wires. In the course of standard maintenance operations on internal components wires can be nicked by workers' pliers or even bent beyond their tolerable radius. These tasks can also leave wiring components sprinkled with metal drill shavings, water, or chemicals. Efforts to work on out-of-reach components can leave non-targeted wiring compromised with the damaged unnoticed as step ladders make contact with weakened insulation.

Even simple moisture condensation can spell trouble, particularly in conjunction with polyimide insulation, which breaks down when exposed to moisture and heat. This is not a good scenario for a vehicle that must contain drip loops in the wiring, because it is normally wringing wet after each flight! Moisture creating a short circuit between compromised wires can cause a tiny arc, gradually carbonize the insulation, and finally result in flashover and fire.

And it isn't just old planes that have problems. In areas such as the wheel well, nearly 1/3 of all planes will have wiring faults within the first year. The hazard of these pervasive "wet arcs" has prompted the development of arc-fault circuit breakers. Ordinary circuit breakers are heat-sensitive bimetal elements that trip only when a large current passes through the circuit long enough to heat the element. This power may be on the order of 1000 percent of the rated current for 0.35 to 0.8 seconds. By comparison, a single arc-fault may last only 1.25 ms, and a series of events may last 20–30 ms. The energy levels here are not enough to trip the circuit breaker yet these arc-faults can cause catastrophic local damage to the wire. Fires have been known to break out with the breaker still providing power to the circuit.

Arc-fault circuit breakers contain sophisticated electronics to sample the current on the wire at sub-millisecond intervals. Both time and frequency domain filtering are used to extract the arc-fault signature

from the current waveform. This signature may be integrated over time to discriminate, by means of pattern matching algorithms, between a normal current and a sputtering arc-fault current. And so ordinary transients like a motor being turned on and off, can be distinguished from the random current surges that occur with arcing. Arc-fault breakers are already required in new home wiring in the United States and are now being miniaturized for use on aircraft.

One of the most significant problems that is limiting the adoption and implementation of arc-fault breakers in aircraft is the lack of a method for locating the tiny damage left on the wire after the breaker has tripped. The left side of Figure 1 (below) shows the damage left after a traditional thermal circuit breaker has tripped. Note that the damage that is clearly visible and could be found with today's typical inspection methods. However, the sustained arcing that caused this damage could have started a fire if flammables had been near the fault when it occurred. The right side of Figure 1 shows the damage left after the arc-fault circuit breaker has tripped. This damage is so slight that the wire is still fully functional and has an impedance discontinuity of less than an ohm. This level of damage to the wire could be extremely difficult or impossible to locate, particularly if the circuit remains functional.

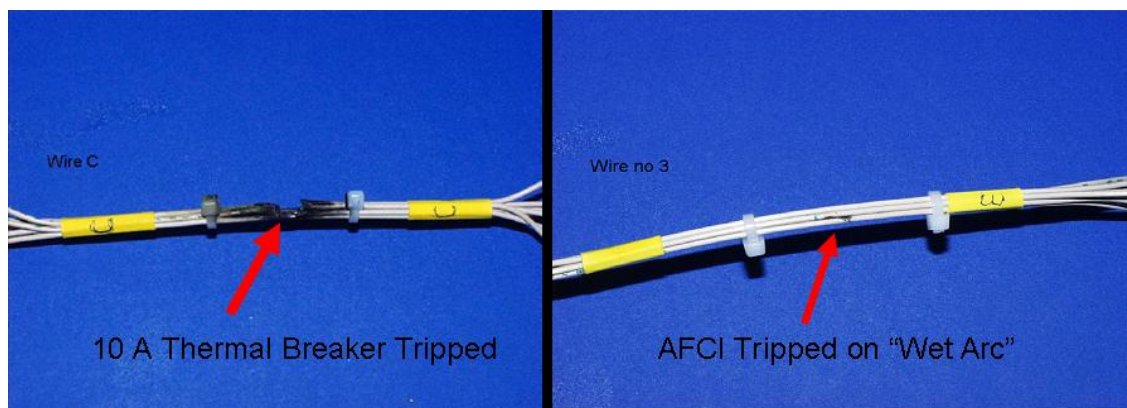

*Figure 1: Samples of polyimide wire that have been tested for wet arcs. Two radial cracks were made 1/4" apart, and several drips of saline solution were dripped over these cracks when the system was energized with three-phase 400 Hz 115V power. The wire on the left shows damage typical of today's thermal breakers, and the wire on the right has damage typical of protection by an arc-fault circuit breaker.*

Visual inspection is still the most common way to check for wiring failures. It entails accessing the cables and then carefully checking the insulation for holes and cracks. Often these holes are no larger than the head of a pin. Unfortunately, entire sections of wiring may never be inspected. Chafed insulation can be hidden under clamps, around corners, or within multi-wire bundles where each bundle can consist of 75 or more wires. And many wire bundles are built right into the walls of the aircraft and hidden cosmetically by panels. For commercial and residential buildings the situation is worse as the wires are usually hidden behind walls that are not meant to be disassembled.

#### *Other Techniques for Diagnosing Wiring Faults*

Another approach to test the wiring involves measuring the cable's resistance and/or capacitance. A low resistance means the cable is "good," and a high resistance means that it is broken. Capacitance is proportional to cable length. While these methods can locate a hard fault on a single (unbranched) cable, they cannot locate small faults or faults on branched networks.

To find small faults such as those left after an arc-fault, a very high voltage (500 V or more) can be placed between adjacent, supposedly unconnected wires. Current leakage from one wire to another can indicate degraded or damaged insulation, although it cannot locate it. To actually locate a small fault with moderate voltage levels, inert gas (such as helium) can be injected near the wire. This decreases the breakdown voltage and causes a tiny arc where the wire insulation is compromised, thus locating small faults. This method is limited by physical access to all parts of the wire under test.

*Reflectometry Methods to the Rescue*

Time Domain Reflectometry (TDR) can be used to trace wiring problems. A short, typically rectangular pulse is sent down the cable to encounter differences in the cable impedance. These differences generate a reflection. Typically the cable impedance, termination, and length all give a unique temporal signature to the reflected signal. A trained technician then interprets the signature to determine the health of the cable and location of any detected faults. Such signal interpretation is particularly necessary for aircraft systems, where wires branch into complicated network structures and connect to active avionics. The running joke about TDR is that “you need a Ph.D. in Electrical Engineering” to read the TDR reflected signatures.

There are other flavors of Reflectometry as well, each with various strengths and weaknesses. Standing-Wave Reflectometry (SWR) and Frequency-Domain Reflectometry (FDR) involve sending a set of stepped sine waves down the wire and measuring the magnitude and / or phase of the reflected wave. These reflectometry methods are not able to locate the tiny faults left after an arc-fault event, because their impedance discontinuities are too small to create a measurable reflection. Mixed Signal Reflectometry (MSR) is similar to the FDR method and SWR method in that it looks for the magnitude of the standing wave. In practice it is slightly more accurate and cost effective than the FDR and SWR devices [6][7][8].

Sequence Time Domain Reflectometry (STDR) and Spread Spectrum Time Domain Reflectometry (SSTDR) operate on the principle of a transmitted pseudo-noise code reflecting back from impedance discontinuities and mismatches. Correlating the reflected signal with the transmitted code yields a measured time shift that indicates the position of the signal reflector. This method has the particular advantage of being able to operate with relatively tiny signal levels making it suitable for testing for intermittent faults on live circuits.

Also available for testing wires non-live wiring are capacitive and inductive sensors. These sensors measure the capacitive and inductive properties of the wires under test. While these are relatively inexpensive and accurate, they are not suitable for testing live circuits.

Figure 2 shows a chart showing the relative merits of the various testing methods. Of note – the only techniques suitable for operating on live circuits are the STDR and SSTDR methods given the need for accuracy and non-interference with circuit communications.

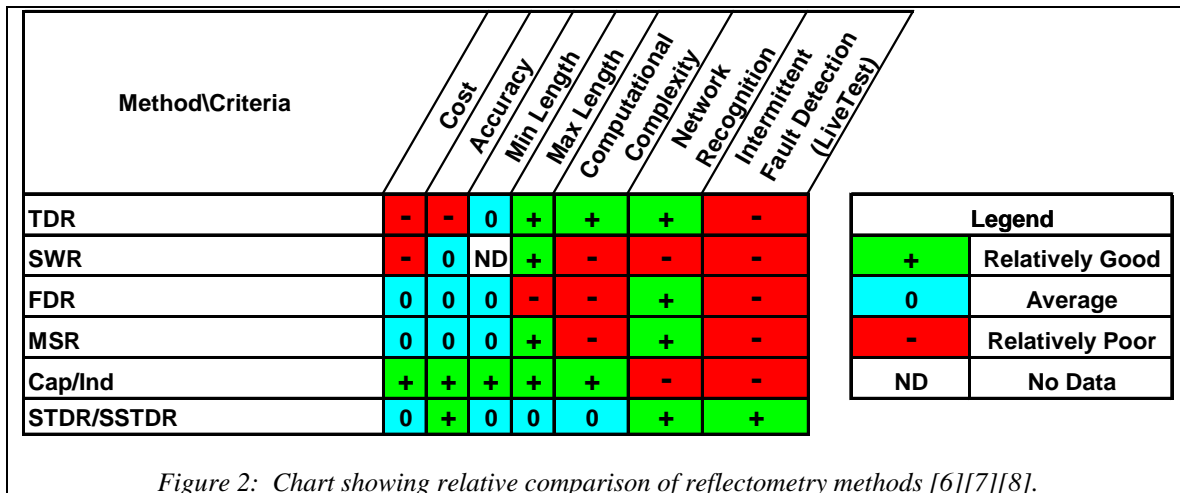

*Spread Spectrum Reflectometry*

It was noted earlier that a key limitation in the adoption of arc-fault circuit breakers was the inability to locate arc-faults in the wires after the arcing event. When one considers that an arc-fault event appears to

be a short circuit to a live test system, a live circuit-monitoring reflectometer is the obvious solution. The STD R/SSTD R reflectometer can detect live arc-faults which can appear for only a few milliseconds. The apparent short circuit will return plenty of reflected power! This realization launched the research in the Utah “Smart Wiring” program, now at the University of Utah Center of Excellence for Smart Sensors. In partnership with the Center of Excellence at the U of U, this technology is being developed for commercial applications at LiveWire Test Labs, Inc.

Spread Spectrum signals have been used in communication and radar for over 50 years. Direct Sequence Spread Spectrum (DSSS) communication uses a high-speed pseudo-noise (PN) code multiplexed with existing digital data to spread the spectrum, increase the number of simultaneous users on the line, and reduce the effects of noise and jamming. This same ability to reduce interference with other “users” and to resist “jamming” provides the ability to test live wires in flight without either interfering with the avionics signals or being corrupted by them. The basic spread spectrum system is shown in Figure 3.

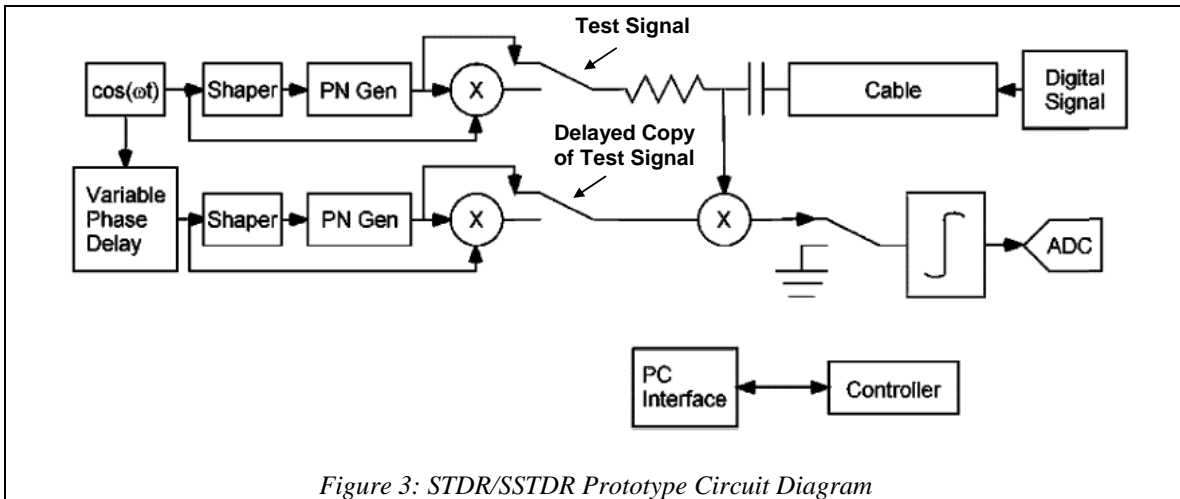

Figure 3: STD R/SSTD R Prototype Circuit Diagram

In order to guarantee no interference with the avionics, the PN code is very small (25-70 dB down) compared to the data signal. Figure 4 shows an example of the SSTD R signal combined with a MIL-STD-1553 communication signal. The SSTD R signal is insignificant and will not interfere with the system communications. In fact, the SSTD R signal is below the noise margin of the data. The PN code is added to the data/noise signal and the combined signal is transmitted down the wire. The transmitted signal then will reflect from the end of the wire or from a fault if a fault is present.

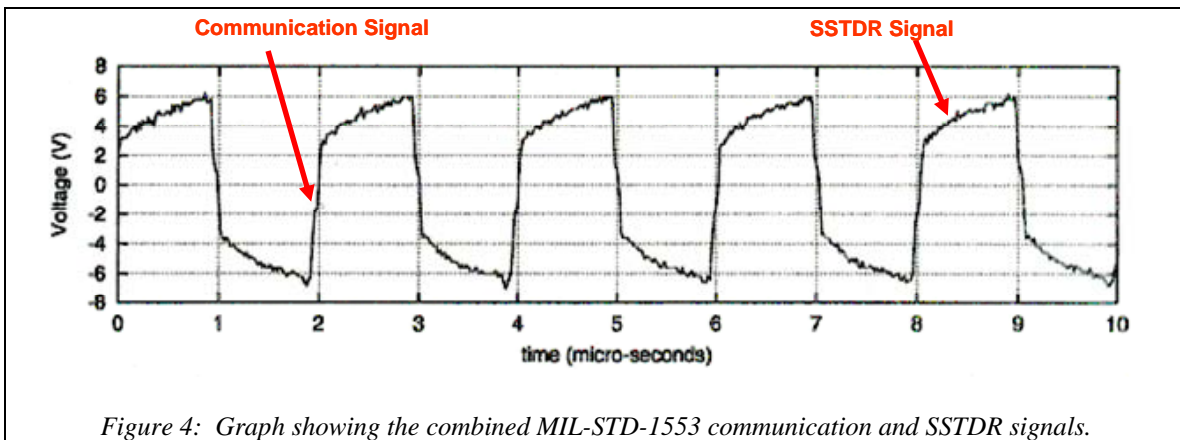
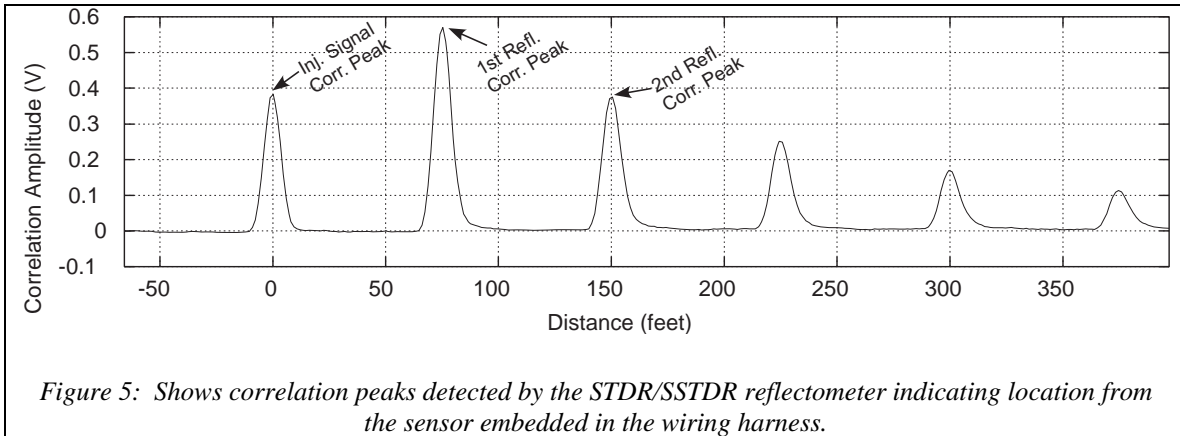

Figure 4: Graph showing the combined MIL-STD-1553 communication and SSTD R signals.

Detection of a fault is achieved when the combined incident/reflected signal is correlated with the delayed PN code. This correlation is high if the two codes are synchronized and low if they are not. The time delay from the start of the SSTDR transmission to the peak of the correlated signal indicates the location of the fault. Figure 5 shows a graph of the correlation peaks indicating distance to fault (in this figure the open end of the wire). Accuracy has been tested and we have recorded fault locations to within 3 inches on a 25 foot cable using SSTDR techniques. This kind of accuracy is needed when locating hard to see faults hidden behind airplane panels or wires embedded in the walls of buildings.



### Conclusion

In summary, the SSTDR Reflectometer is capable of running live, with the test signal completely buried within the system noise levels. It can locate intermittent faults a few milliseconds long to within a few centimeters over tens to hundreds of meters of wire. This technology can detect the location of arc-faults on live wires with arc-fault breakers in position to shutdown the circuit and prevent fires. The fault sensors can report the location immediately or store the data for later analysis.

A method that can run on live wires that can locate millisecond faults which doesn't interfere with the existing aircraft signals has tremendous promise for other applications. Power wires in residential and commercial building that have multiple branches and create multiple reflections are not out of bounds for this technology. Yet, the residents of these buildings demand that safety is foremost in the minds of all those concerned with maintaining the wires in the power delivery systems. The challenge here is to build a diagnostic tool that is suitable for the detection of problems without false alarms. The designed immunity to false alarms needs to take into consideration fans, motors, computers, and entertainment systems that can plug in and out of the wiring on a random basis. In addition, the instrument must be suitable for a very cost sensitive market place. Our efforts are working towards integrating this technology cost effectively into the arc-fault circuit breakers, into the connectors between the wires, and eventually into the wires themselves.

*References:*

- [1] J. Jonnes, *Empires of Light: Edison, Tesla, Westinghouse, and the Race to Electrify the World*, New York, NY, Random House, 2003, ISBN: 978-0-375-75884-3.
- [2] <http://www.usfa.dhs.gov/safety/tips/electrical.shtm> , October 2006.
- [3] <http://www.cdc.gov/ncipc/factsheets/fire.htm>, October 2006.
- [4] M. Ahrens, "Current Fire Statistics Related to Electrical Fires," *Aged Electrical Systems Research Application Symposium*, Chicago, IL, NFPA, October 18-19, 2006.
- [5] [http://www.swissair111.org/md11\\_wiring\\_photos.htm](http://www.swissair111.org/md11_wiring_photos.htm)
- [6] <http://www.fbodaily.com/archive/2005/04-April/30-Apr-2005/FBO-00797603.htm>
- [7] C. Furse, Y.C. Chung, C. Lo, P. Pendayala, "A Critical Comparison of reflectometry methods for location of wiring faults," *Smart Structures and Systems*, Vol. 2, pp. 25-46, 2006.
- [8] <http://www.eclipse.org/DownLoads/ESP%20plus%20FLYER.pdf>
- [9] C. Furse, "Finding Fault: Locating Hidden Hazards on Aircraft Wiring," *University of Utah College of Engineering Newsletter*, pp. 1-4, February 2004.

**Authors:*****Paul K. Kuhn, Ph.D.******Principal Engineer, LiveWire Test Labs, Inc.***

Dr. Kuhn (PhD '91) joined LiveWire Test Labs, Inc. in April 2006 as a Principal Engineer to help the team with the design and development of electronic hardware and detection algorithms for finding faults in wiring systems. LiveWire Test Labs is a spin-off company that is developing instrumentation systems to locate faults and hazards in wiring systems. LiveWire's instrumentation is based on the spread spectrum sensing technology being developed at the University of Utah. Prior to joining LiveWire Test Labs, Dr. Kuhn was a Principal Systems Engineer, Systems Architect, and Six-Sigma Black Belt with GE Healthcare's Interventional, Cardiology and Surgery Division (formerly OEC Medical Systems) in Salt Lake City, Utah. At GE Healthcare, his responsibilities included the research, design and development, and systems architecture of the OEC Mobile C-arm X-ray imaging systems and the related family of products. Dr. Kuhn has over 25 years experience as a researcher, developer, teacher, and consultant in the fields of computer based instrumentation, medical imaging systems, systems engineering, and electrical and electronics engineering.

***Cynthia Furse, Ph.D.******Professor, Dept. Electrical and Computer Engineering, University of Utah***

Dr. Furse (PhD '94) is the Director of the Center of Excellence for Smart Sensors at the University of Utah and Professor in the Electrical and Computer Engineering Department. The Center focuses on imbedded antennas and sensors in complex environments, such as telemetry systems in the human body, and sensors for location of faults on aging aircraft wiring. Dr. Furse has directed the Utah "Smart Wiring" program, sponsored by NAVAIR and USAF, since 1998. She is Head of Research for LiveWire Test Labs, Inc., a spin off company commercializing devices to locate intermittent faults on live wires. Dr. Furse teaches electromagnetics, wireless communication, computational electromagnetics, microwave engineering, and antenna design. Dr. Furse was the Professor of the Year in the College of Engineering at Utah State University for the year 2000, Faculty Employee of the year 2002, a National Science Foundation Computational and Information Sciences and Engineering Graduate Fellow, IEEE Microwave Theory and Techniques Graduate Fellow, and President's Scholar at the University of Utah. She is the chair of the IEEE Antennas and Propagation Society Education Committee, and Editor-in-Chief of the International Journal of Antennas and Propagation.

***Paul Smith, Ph.D.******President, LiveWire Test Labs, Inc.***

Dr. Smith (PhD '03) is one of the founders of LiveWire Test Labs, Inc. LiveWire Test Labs is a spin-off company that is developing instrumentation systems to locate faults and hazards in wiring systems. LiveWire's instrumentation is based on the spread spectrum sensing technology being developed at the University of Utah. Dr. Smith has focused his career on solutions to difficult wire test issues and has over fifteen years experience providing cable and wire harness test equipment for commercial and military applications. Dr. Smith has been awarded multiple patents in the field.