

2009 Fall Revision Cycle

Report on Proposals

A compilation of NFPA® Technical Committee Reports on Proposals for public review and comment

Public Comment Deadline: March 6, 2009

NOTE: The proposed NFPA documents addressed in this Report on Proposals (ROP) and in a follow-up Report on Comments (ROC) will only be presented for action at the NFPA June 2010 Association Technical Meeting to be held June 7–11, 2010, at Mandalay Bay Convention Center in Las Vegas, NV, when proper Amending Motions have been submitted to the NFPA by the deadline of October 23, 2009. Documents that receive no motions will not be presented at the meeting and instead will be forwarded directly to the Standards Council for action on issuance. For more information on the rules and for up-to-date information on schedules and deadlines for processing NFPA documents, check the NFPA website (www.nfpa.org) or contact NFPA Standards Administration.



National Fire Protection Association®

1 BATTERYMARCH PARK, QUINCY, MA 02169-7471

Information on NFPA Codes and Standards Development

I. Applicable Regulations. The primary rules governing the processing of NFPA documents (codes, standards, recommended practices, and guides) are the *NFPA Regulations Governing Committee Projects (RGCPs)*. Other applicable rules include *NFPA Bylaws*, *NFPA Technical Meeting Convention Rules*, *NFPA Guide for the Conduct of Participants in the NFPA Standards Development Process*, and the *NFPA Regulations Governing Petitions to the Board of Directors from Decisions of the Standards Council*. These rules and regulations are contained in the *NFPA Directory*. For copies of the *Directory*, contact Codes and Standards Administration at NFPA Headquarters; these documents are also available on the NFPA website at “www.nfpa.org.”

The following is general information on the NFPA process. All participants, however, should refer to the actual rules and regulations for a full understanding of this process and for the criteria that govern participation.

II. Technical Committee Report (TCR). The Technical Committee Report is defined as “the Report of the Technical Committee and Technical Correlating Committee (if any) on a document. A Technical Committee Report consists of the Report on Proposals (ROP), as modified by the Report on Comments (ROC), published by the Association” (see 1.4 of *RGCPs*).

III. Step 1: Report on Proposals (ROP). The ROP is defined as “a report to the Association on the actions taken by Technical Committees and/or Technical Correlating Committees, accompanied by a ballot statement and one or more proposals on text for a new document or to amend an existing document” (see 1.4 of *RGCPs*). Any objection to an action in the ROP must be raised through the filing of an appropriate Comment for consideration in the ROC or the objection will be considered resolved.

IV. Step 2: Report on Comments (ROC). The ROC is defined as “a report to the Association on the actions taken by Technical Committees and/or Technical Correlating Committees accompanied by a ballot statement and one or more comments resulting from public review of the Report on Proposals (ROP)” (see 1.4 of *RGCPs*). The ROP and the ROC together constitute the Technical Committee Report. Any outstanding objection following the ROC must be raised through an appropriate Amending Motion at the Association Technical Meeting or the objection will be considered resolved.

V. Step 3a: Action at Association Technical Meeting. Following the publication of the ROC, there is a period during which those wishing to make proper Amending Motions on the Technical Committee Reports must signal their intention by submitting a Notice of Intent to Make a Motion. Documents that receive notice of proper Amending Motions (Certified Amending Motions) will be presented for action at the annual June Association Technical Meeting. At the meeting, the NFPA membership can consider and act on these Certified Amending Motions as well as Follow-up Amending Motions, that is, motions that become necessary as a result of a previous successful Amending Motion. (See 4.6.2 through 4.6.9 of *RGCPs* for a summary of the available Amending Motions and who may make them.) Any outstanding objection following action at an Association Technical Meeting (and any further Technical Committee consideration following successful Amending Motions, see *RGCPs* at 4.7) must be raised through an appeal to the Standards Council or it will be considered to be resolved.

VI. Step 3b: Documents Forwarded Directly to the Council. Where no Notice of Intent to Make a Motion is received and certified in accordance with the Technical Meeting Convention Rules, the document is forwarded directly to the Standards Council for action on issuance. Objections are deemed to be resolved for these documents.

VII. Step 4a: Council Appeals. Anyone can appeal to the Standards Council concerning procedural or substantive matters related to the development, content, or issuance of any document of the Association or on matters within the purview of the authority of the Council, as established by the *Bylaws* and as determined by the Board of Directors. Such appeals must be in written form and filed with the Secretary of the Standards Council (see 1.6 of *RGCPs*). Time constraints for filing an appeal must be in accordance with 1.6.2 of the *RGCPs*. Objections are deemed to be resolved if not pursued at this level.

VIII. Step 4b: Document Issuance. The Standards Council is the issuer of all documents (see Article 8 of *Bylaws*). The Council acts on the issuance of a document presented for action at an Association Technical Meeting within sixty days from the date of the recommendation from the Association Technical Meeting, unless this period is extended by the Council (see 4.8 of *RGCPs*). For documents forwarded directly to the Standards Council, the Council acts on the issuance of the document at its next scheduled meeting, or at such other meeting as the Council may determine (see 4.5.7 and 4.8 of *RGCPs*).

IX. Petitions to the Board of Directors. The Standards Council has been delegated the responsibility for the administration of the codes and standards development process and the issuance of documents. However, where extraordinary circumstances requiring the intervention of the Board of Directors exist, the Board of Directors may take any action necessary to fulfill its obligations to preserve the integrity of the codes and standards development process and to protect the interests of the Association. The rules for petitioning the Board of Directors can be found in the *Regulations Governing Petitions to the Board of Directors from Decisions of the Standards Council* and in 1.7 of the *RGCPs*.

X. For More Information. The program for the Association Technical Meeting (as well as the NFPA website as information becomes available) should be consulted for the date on which each report scheduled for consideration at the meeting will be presented. For copies of the ROP and ROC as well as more information on NFPA rules and for up-to-date information on schedules and deadlines for processing NFPA documents, check the NFPA website (www.nfpa.org) or contact NFPA Codes & Standards Administration at (617-984-7246).

2009 Fall Revision Cycle ROP Contents

by NFPA Numerical Designation

Note: Documents appear in numerical order.

NFPA No.	Type Action	Title	Page No.
10	P	Standard for Portable Fire Extinguishers	10-1
11	P	Standard for Low-, Medium-, and High-Expansion Foam.....	11-1
13E	P	Recommended Practice for Fire Department Operations in Properties Protected by Sprinkler and Standpipe Systems.....	13E-1
14	P	Standard for the Installation of Standpipe and Hose Systems.....	14-1
18	P	Standard on Wetting Agents	18-1
37	P	Standard for the Installation and Use of Stationary Combustion Engines and Gas Turbines	37-1
45	P	Standard on Fire Protection for Laboratories Using Chemicals.....	45-1
53	P	Recommended Practice on Materials, Equipment, and Systems Used in Oxygen-Enriched Atmospheres	53-1
70B	P	Recommended Practice for Electrical Equipment Maintenance	70B-1
91	P	Standard for Exhaust Systems for Air Conveying of Vapors, Gases, Mists, and Noncombustible Particulate Solids	91-1
120	P	Standard for Fire Prevention and Control in Coal Mines	120-1
122	P	Standard for Fire Prevention and Control in Metal/Nonmetal Mining and Metal Mineral Processing Facilities.....	122-1
204	P	Standard for Smoke and Heat Venting	204-1
211	P	Standard for Chimneys, Fireplaces, Vents, and Solid Fuel-Burning Appliances	211-1
214	P	Standard on Water-Cooling Towers	214-1
255	W	Standard Method of Test of Surface Burning Characteristics of Building Materials	255-1
276	N	Standard Method of Fire Test for Determining the Heat Release Rate of Roofing Assemblies with Combustible Above-Deck Roofing Components	276-1
326	P	Standard for the Safeguarding of Tanks and Containers for Entry, Cleaning, or Repair	326-1
329	P	Recommended Practice for Handling Releases of Flammable and Combustible Liquids and Gases	329-1
405	P	Standard for the Recurring Proficiency of Airport Fire Fighters	405-1
408	P	Standard for Aircraft Hand Portable Fire Extinguishers	408-1
409	P	Standard on Aircraft Hangars	409-1
410	P	Standard on Aircraft Maintenance	410-1
422	P	Guide for Aircraft Accident/Incident Response Assessment	422-1
423	P	Standard for Construction and Protection of Aircraft Engine Test Facilities	423-1
495	P	Explosive Materials Code	495-1
498	R	Standard for Safe Havens and Interchange Lots for Vehicles Transporting Explosives	498-1
505	P	Fire Safety Standard for Powered Industrial Trucks Including Type Designations, Areas of Use, Conversions, Maintenance, and Operations	505-1
520	P	Standard on Subterranean Spaces	520-1

551	P	Guide for the Evaluation of Fire Risk Assessments	551-1
600	R	Standard on Industrial Fire Brigades	600-1
601	R	Standard for Security Services in Fire Loss Prevention	601-1
701	P	Standard Methods of Fire Tests for Flame Propagation of Textiles and Films	701-1
750	P	Standard on Water Mist Fire Protection Systems	750-1
804	P	Standard for Fire Protection for Advanced Light Water Reactor Electric Generating Plants	804-1
805	P	Performance-Based Standard for Fire Protection for Light Water Reactor Electric Generating Plants.....	805-1
806	N	Performance-Based Standard for Fire Protection for Advanced Nuclear Reactor Electric Generating Plants.....	806-1
850	P	Recommended Practice for Fire Protection for Electric Generating Plants and High Voltage Direct Current Converter Stations.....	850-1
851	P	Recommended Practice for Fire Protection for Hydroelectric Generating Plants	851-1
853	P	Standard for the Installation of Stationary Fuel Cell Power Systems	853-1
900	P	Building Energy Code.....	900-1
914	P	Code for Fire Protection of Historic Structures	914-1
1003	P	Standard for Airport Fire Fighter Professional Qualifications	1003-1
1035	P	Standard for Professional Qualifications for Public Fire and Life Safety Educator	1035-1
1150	P	Standard on Foam Chemicals for Fires in Class A Fuels	1150-1
1201	C	Standard for Providing Emergency Services to the Public.....	1201-1
1250	P	Recommended Practice in Emergency Service Organization Risk Management.....	1250-1
1407	N	Standard for Fire Service Rapid Intervention Crews.....	1407-1
1410	P	Standard on Training for Initial Emergency Scene Operations.....	1410-1
1452	P	Guide for Training Fire Service Personnel to Conduct Dwelling Fire Safety Surveys	1452-1
1581	P	Standard on Fire Department Infection Control Program	1581-1
1600	C	Standard on Disaster/Emergency Management and Business Continuity Programs.....	1600-1
1620	C	Recommended Practice for Pre-Incident Planning.....	1620-1
1801	N	Standard on Thermal Imagers for the Fire Service.....	1801-1
1931	P	Standard for Manufacturer’s Design of Fire Department Ground Ladders	1931-1
1932	P	Standard on Use, Maintenance, and Service Testing of In-Service Fire Department Ground Ladders	1932-1
1936	P	Standard on Powered Rescue Tools.....	1936-1
1952	N	Standard on Surface Water Operations Protective Clothing and Equipment.....	1952-1
1977	P	Standard on Protective Clothing and Equipment for Wildland Fire Fighting.....	1977-1
2010	P	Standard for Fixed Aerosol Fire-Extinguishing Systems	2010-1

**2009 Fall Revision Cycle ROP
Committees Reporting**

		Type Action	Page No.
Aerosol Extinguishing Technology			
2010	Standard for Fixed Aerosol Fire-Extinguishing Systems	P	2010-1
Aircraft Maintenance Operations			
410	Standard on Aircraft Maintenance	P	410-1
Aircraft Rescue and Fire Fighting			
405	Standard for the Recurring Proficiency of Airport Fire Fighters	P	405-1
408	Standard for Aircraft Hand Portable Fire Extinguishers	P	408-1
422	Guide for Aircraft Accident/Incident Response Assessment	P	422-1
Airport Facilities			
409	Standard on Aircraft Hangars	P	409-1
423	Standard for Construction and Protection of Aircraft Engine Test Facilities	P	423-1
Building Systems			
900	Building Energy Code	P	900-1
Chimneys, Fireplaces, and Venting Systems for Heat-Producing Appliances			
211	Standard for Chimneys, Fireplaces, Vents, and Solid Fuel–Burning Appliances	P	211-1
Cultural Resources			
914	Code for Fire Protection of Historic Structures	P	914-1
Electric Generating Plants			
850	Recommended Practice for Fire Protection for Electric Generating Plants and High Voltage Direct Current Converter Stations	P	850-1
851	Recommended Practice for Fire Protection for Hydroelectric Generating Plants	P	851-1
853	Standard for the Installation of Stationary Fuel Cell Power Systems	P	853-1
Electrical Equipment Maintenance			
70B	Recommended Practice for Electrical Equipment Maintenance	P	70B-1
Emergency Management and Business Continuity			
1600	Standard on Disaster/Emergency Management and Business Continuity Programs	C	1600-1
Emergency Service Organization Risk Management			
1201	Standard for Providing Emergency Services to the Public	C	1201-1
1250	Recommended Practice in Emergency Service Organization Risk Management	P	1250-1
Explosives			
495	Explosive Materials Code	P	495-1
498	Standard for Safe Havens and Interchange Lots for Vehicles Transporting Explosives	R	498-1
Fire and Emergency Services Protective Clothing and Equipment			
Electronic Safety Equipment			
1801	Standard on Thermal Imagers for the Fire Service	N	1801-1
Special Operations Protective Clothing and Equipment			
1952	Standard on Surface Water Operations Protective Clothing and Equipment	N	1952-1
Wildland Fire Fighting Protective Clothing and Equipment			
1977	Standard on Protective Clothing and Equipment for Wildland Fire Fighting	P	1977-1
Fire Department Ground Ladders			
1931	Standard for Manufacturer’s Design of Fire Department Ground Ladders	P	1931-1
1932	Standard on Use, Maintenance, and Service Testing of In-Service Fire Department Ground Ladders	P	1932-1
Fire Department Rescue Tools			
1936	Standard on Powered Rescue Tools	P	1936-1

Fire Protection for Nuclear Facilities				
804	Standard for Fire Protection for Advanced Light Water Reactor Electric Generating Plants	P		804-1
805	Performance-Based Standard for Fire Protection for Light Water Reactor Electric Generating Plants	P		805-1
806	Performance-Based Standard for Fire Protection for Advanced Nuclear Reactor Electric Generating Plants	N		806-1
Fire Risk Assessment Methods				
551	Guide for the Evaluation of Fire Risk Assessments	P		551-1
Fire Service Occupational Safety and Health				
1581	Standard on Fire Department Infection Control Program	P		1581-1
Fire Service Training				
13E	Recommended Practice for Fire Department Operations in Properties Protected by Sprinkler and Standpipe Systems	P		13E-1
1407	Standard for Fire Service Rapid Intervention Crews	N		1407-1
1410	Standard on Training for Initial Emergency Scene Operations	P		1410-1
1452	Guide for Training Fire Service Personnel to Conduct Dwelling Fire Safety Surveys	P		1452-1
Fire Tests				
255	Standard Method of Test of Surface Burning Characteristics of Building Materials	W		255-1
276	Standard Method of Fire Test for Determining the Heat Release Rate of Roofing Assemblies with Combustible Above-Deck Roofing Components	N		276-1
701	Standard Methods of Fire Tests for Flame Propagation of Textiles and Films	P		701-1
Foam				
11	Standard for Low-, Medium-, and High-Expansion Foam	P		11-1
Forest and Rural Fire Protection				
1150	Standard on Foam Chemicals for Fires in Class A Fuels	P		1150-1
Handling and Conveying of Dusts, Vapors, and Gases				
91	Standard for Exhaust Systems for Air Conveying of Vapors, Gases, Mists, and Noncombustible Particulate Solids	P		91-1
Industrial Trucks				
505	Fire Safety Standard for Powered Industrial Trucks Including Type Designations, Areas of Use, Conversions, Maintenance, and Operations	P		505-1
Internal Combustion Engines				
37	Standard for the Installation and Use of Stationary Combustion Engines and Gas Turbines	P		37-1
Laboratories Using Chemicals				
45	Standard on Fire Protection for Laboratories Using Chemicals	P		45-1
Loss Prevention Procedures and Practices				
600	Standard on Industrial Fire Brigades	R		600-1
601	Standard for Security Services in Fire Loss Prevention	R		601-1
Mining Facilities				
120	Standard for Fire Prevention and Control in Coal Mines	P		120-1
122	Standard for Fire Prevention and Control in Metal/Nonmetal Mining and Metal Mineral Processing Facilities	P		122-1
Oxygen-Enriched Atmospheres				
53	Recommended Practice on Materials, Equipment, and Systems Used in Oxygen-Enriched Atmospheres	P		53-1
Portable Fire Extinguishers				
10	Standard for Portable Fire Extinguishers	P		10-1

Pre-Incident Planning			
1620	Recommended Practice for Pre-Incident Planning	C	1620-1
Professional Qualifications			
Fire Fighter Professional Qualifications			
1003	Standard for Airport Fire Fighter Professional Qualifications	P	1003-1
Public Fire Educator Professional Qualifications			
1035	Standard for Professional Qualifications for Public Fire and Life Safety Educator	P	1035-1
Smoke Management Systems			
204	Standard for Smoke and Heat Venting	P	204-1
Standpipes			
14	Standard for the Installation of Standpipe and Hose Systems	P	14-1
Subterranean Spaces			
520	Standard on Subterranean Spaces	P	520-1
Tank Leakage and Repair Safeguards			
326	Standard for the Safeguarding of Tanks and Containers for Entry, Cleaning, or Repair	P	326-1
329	Recommended Practice for Handling Releases of Flammable and Combustible Liquids and Gases	P	329-1
Water Additives for Fire Control and Vapor Mitigation			
18	Standard on Wetting Agents	P	18-1
Water-Cooling Towers			
214	Standard on Water-Cooling Towers	P	214-1
Water Mist Fire Suppression Systems			
750	Standard on Water Mist Fire Protection Systems	P	750-1

Key to Proposal Headings

The first line of every proposal includes the following information:

Document No.	Proposal No.	Log No.	Paragraph Reference	Committee Action
101	6	38	3.4	Accept

Example: 101-6 Log #38
(3.4)

Final Action: Accept

TYPES OF ACTION

P Partial Revision **C** Complete Revision **N** New Document **R** Reconfirmation **W** Withdrawal

The following classifications apply to Committee members and represent their principal interest in the activity of the Committee.

1. **M** Manufacturer: A representative of a maker or marketer of a product, assembly, or system, or portion thereof, that is affected by the standard.
2. **U** User: A representative of an entity that is subject to the provisions of the standard or that voluntarily uses the standard.
3. **IM** Installer/Maintainer: A representative of an entity that is in the business of installing or maintaining a product, assembly, or system affected by the standard.
4. **L** Labor: A labor representative or employee concerned with safety in the workplace.
5. **RT** Applied Research/Testing Laboratory: A representative of an independent testing laboratory or independent applied research organization that promulgates and/or enforces standards.
6. **E** Enforcing Authority: A representative of an agency or an organization that promulgates and/or enforces standards.
7. **I** Insurance: A representative of an insurance company, broker, agent, bureau, or inspection agency.
8. **C** Consumer: A person who is or represents the ultimate purchaser of a product, system, or service affected by the standard, but who is not included in (2).
9. **SE** Special Expert: A person not representing (1) through (8) and who has special expertise in the scope of the standard or portion thereof.

NOTE 1: "Standard" connotes code, standard, recommended practice, or guide.

NOTE 2: A representative includes an employee.

NOTE 3: While these classifications will be used by the Standards Council to achieve a balance for Technical Committees, the Standards Council may determine that new classifications of member or unique interests need representation in order to foster the best possible Committee deliberations on any project. In this connection, the Standards Council may make such appointments as it deems appropriate in the public interest, such as the classification of "Utilities" in the National Electrical Code Committee.

NOTE 4: Representatives of subsidiaries of any group are generally considered to have the same classification as the parent organization.

**FORM FOR COMMENTS ON NFPA REPORT ON PROPOSALS
2009 FALL REVISION CYCLE
FINAL DATE FOR RECEIPT OF COMMENTS: 5:00 pm EST, March 6, 2009**

For further information on the standards-making process, please contact the Codes and Standards Administration at 617-984-7249 or visit www.nfpa.org/codes.

For technical assistance, please call NFPA at 1-800-344-3555.

FOR OFFICE USE ONLY

Log #: _____

Date Rec'd: _____

Please indicate in which format you wish to receive your ROP/ROC electronic paper download
(Note: If choosing the download option, you must view the ROP/ROC from our website; no copy will be sent to you.)

Date 8/1/200X Name John B. Smith Tel. No. 253-555-1234

Company _____ Email _____

Street Address 9 Seattle St. City Tacoma State WA Zip 98402

***If you wish to receive a hard copy, a street address MUST be provided. Deliveries cannot be made to PO boxes.

Please indicate organization represented (if any) Fire Marshals Assn. of North America

1. (a) NFPA Document Title National Fire Alarm Code NFPA No. & Year NFPA 72, 200X ed.

(b) Section/Paragraph 4.4.1.1

2. Comment on Proposal No. (from ROP): 72-7

3. Comment Recommends (check one): new text revised text deleted text

4. Comment (include proposed new or revised wording, or identification of wording to be deleted): [Note: Proposed text should be in legislative format; i.e., use underscore to denote wording to be inserted (inserted wording) and strike-through to denote wording to be deleted (~~deleted wording~~).]

Delete exception.

5. **Statement of Problem and Substantiation for Comment:** (Note: State the problem that would be resolved by your recommendation; give the specific reason for your Comment, including copies of tests, research papers, fire experience, etc. If more than 200 words, it may be abstracted for publication.)

A properly installed and maintained system should be free of ground faults. The occurrence of one or more ground faults should be required to cause a 'trouble' signal because it indicates a condition that could contribute to future malfunction of the system. Ground fault protection has been widely available on these systems for years and its cost is negligible. Requiring it on all systems will promote better installations, maintenance and reliability.

6. Copyright Assignment

(a) I am the author of the text or other material (such as illustrations, graphs) proposed in this Comment.

(b) Some or all of the text or other material proposed in this Comment was not authored by me. Its source is as follows (please identify which material and provide complete information on its source):

I agree that any material that I author, either individually or with others, in connection with work performed by an NFPA Technical Committee shall be considered to be works made for hire for the NFPA. To the extent that I retain any rights in copyright as to such material, or as to any other material authored by me that I submit for the use of an NFPA Technical Committee in the drafting of an NFPA code, standard, or other NFPA document, I hereby grant and assign all and full rights in copyright to the NFPA. I further agree and acknowledge that I acquire no rights in any publication of the NFPA and that copyright and all rights in materials produced by NFPA Technical Committees are owned by the NFPA and that the NFPA may register copyright in its own name.

Signature (Required) _____

PLEASE USE SEPARATE FORM FOR EACH COMMENT • email: proposals_comments@nfpa.org • NFPA Fax: (617) 770-3500
Mail to: Secretary, Standards Council, National Fire Protection Association, 1 Batterymarch Park, Quincy, MA 02169-7471

**FORM FOR COMMENTS ON NFPA REPORT ON PROPOSALS
2009 FALL REVISION CYCLE
FINAL DATE FOR RECEIPT OF COMMENTS: 5:00 pm EST, March 6, 2009**

For further information on the standards-making process, please contact the Codes and Standards Administration at 617-984-7249 or visit www.nfpa.org/codes.

For technical assistance, please call NFPA at 1-800-344-3555.

FOR OFFICE USE ONLY

Log #: _____

Date Rec'd: _____

Please indicate in which format you wish to receive your ROP/ROC electronic paper download
(Note: If choosing the download option, you must view the ROP/ROC from our website; no copy will be sent to you.)

Date _____ Name _____ Tel. No. _____

Company _____ Email _____

Street Address _____ City _____ State _____ Zip _____

***If you wish to receive a hard copy, a street address **MUST** be provided. Deliveries cannot be made to PO boxes.

Please indicate organization represented (if any) _____

1. (a) NFPA Document Title _____ NFPA No. & Year _____

(b) Section/Paragraph _____

2. Comment on Proposal No. (from ROP): _____

3. Comment Recommends (check one): new text revised text deleted text

4. Comment (include proposed new or revised wording, or identification of wording to be deleted): [Note: Proposed text should be in legislative format; i.e., use underscore to denote wording to be inserted (inserted wording) and strike-through to denote wording to be deleted (~~deleted wording~~).]

5. **Statement of Problem and Substantiation for Comment:** (Note: State the problem that would be resolved by your recommendation; give the specific reason for your Comment, including copies of tests, research papers, fire experience, etc. If more than 200 words, it may be abstracted for publication.)

6. Copyright Assignment

(a) I am the author of the text or other material (such as illustrations, graphs) proposed in this Comment.

(b) Some or all of the text or other material proposed in this Comment was not authored by me. Its source is as follows (please identify which material and provide complete information on its source):

I agree that any material that I author, either individually or with others, in connection with work performed by an NFPA Technical Committee shall be considered to be works made for hire for the NFPA. To the extent that I retain any rights in copyright as to such material, or as to any other material authored by me that I submit for the use of an NFPA Technical Committee in the drafting of an NFPA code, standard, or other NFPA document, I hereby grant and assign all and full rights in copyright to the NFPA. I further agree and acknowledge that I acquire no rights in any publication of the NFPA and that copyright and all rights in materials produced by NFPA Technical Committees are owned by the NFPA and that the NFPA may register copyright in its own name.

Signature (Required) _____

**PLEASE USE SEPARATE FORM FOR EACH COMMENT • email: proposals_comments@nfpa.org • NFPA Fax: (617) 770-3500
Mail to: Secretary, Standards Council, National Fire Protection Association, 1 Batterymarch Park, Quincy, MA 02169-7471**

10/31/2008

Sequence of Events Leading to Issuance of an NFPA Committee Document

Step 1 Call for Proposals

▼ Proposed new document or new edition of an existing document is entered into one of two yearly revision cycles, and a Call for Proposals is published.

Step 2 Report on Proposals (ROP)

▼ Committee meets to act on Proposals, to develop its own Proposals, and to prepare its Report.

▼ Committee votes by written ballot on Proposals. If two-thirds approve, Report goes forward. Lacking two-thirds approval, Report returns to Committee.

▼ Report on Proposals (ROP) is published for public review and comment.

Step 3 Report on Comments (ROC)

▼ Committee meets to act on Public Comments to develop its own Comments, and to prepare its report.

▼ Committee votes by written ballot on Comments. If two-thirds approve, Report goes forward. Lacking two-thirds approval, Report returns to Committee.

▼ Report on Comments (ROC) is published for public review.

Step 4 Technical Committee Report Session

▼ “*Notices of intent to make a motion*” are filed, are reviewed, and valid motions are certified for presentation at the Technical Committee Report Session. (“Consent Documents” that have no certified motions bypass the Technical Committee Report Session and proceed to the Standards Council for issuance.)

▼ NFPA membership meets each June at the Annual Meeting Technical Committee Report Session and acts on Technical Committee Reports (ROP and ROC) for documents with “certified amending motions.”

▼ Committee(s) vote on any amendments to Report approved at NFPA Annual Membership Meeting.

Step 5 Standards Council Issuance

▼ Notification of intent to file an appeal to the Standards Council on Association action must be filed within 20 days of the NFPA Annual Membership Meeting.

▼ Standards Council decides, based on all evidence, whether or not to issue document or to take other action, including hearing any appeals.

The Technical Committee Report Session of the NFPA Annual Meeting

The process of public input and review does not end with the publication of the ROP and ROC. Following the completion of the Proposal and Comment periods, there is yet a further opportunity for debate and discussion through the Technical Committee Report Sessions that take place at the NFPA Annual Meeting.

The Technical Committee Report Session provides an opportunity for the final Technical Committee Report (i.e., the ROP and ROC) on each proposed new or revised code or standard to be presented to the NFPA membership for the debate and consideration of motions to amend the Report. The specific rules for the types of motions that can be made and who can make them are set forth in NFPA's rules, which should always be consulted by those wishing to bring an issue before the membership at a Technical Committee Report Session. The following presents some of the main features of how a Report is handled.

What Amending Motions Are Allowed. The Technical Committee Reports contain many Proposals and Comments that the Technical Committee has rejected or revised in whole or in part. Actions of the Technical Committee published in the ROP may also eventually be rejected or revised by the Technical Committee during the development of its ROC. The motions allowed by NFPA rules provide the opportunity to propose amendments to the text of a proposed code or standard based on these published Proposals, Comments, and Committee actions. Thus, the list of allowable motions include motions to accept Proposals and Comments in whole or in part as submitted or as modified by a Technical Committee action. Motions are also available to reject an accepted Comment in whole or part. In addition, Motions can be made to return an entire Technical Committee Report or a portion of the Report to the Technical Committee for further study.

The NFPA Annual Meeting, also known as the NFPA World Safety Conference & Exposition®, takes place in June of each year. A second Fall membership meeting was discontinued in 2004, so the NFPA Technical Committee Report Session now runs once each year at the Annual Meeting in June.

Who Can Make Amending Motions. NFPA rules also define those authorized to make amending motions. In many cases, the maker of the motion is limited by NFPA rules to the original submitter of the Proposal or Comment or his or her duly authorized representative. In other cases, such as a Motion to Reject an accepted Comment, or to Return a Technical Committee Report or a portion of a Technical Committee Report for Further Study, anyone can make these motions. For a complete explanation, NFPA rules should be consulted.

The Filing of a Notice of Intent to Make a Motion. Before making an allowable motion at a Technical Report Session, the intended maker of the motion must file, in advance of the session, and within the published deadline, a Notice of Intent to Make a Motion. A Motions Committee appointed by the Standards Council then reviews all notices and certifies all amending motions that are proper. The Motions Committee can also, in consultation with the makers of the motions, clarify the intent of the motions and, in certain circumstances, combine motions that are dependent on each other together so that they can be made in one single motion. A Motions Committee report is then made available in advance of the meeting listing all certified motions. Only these Certified Amending Motions, together with certain allowable Follow-Up Motions (that is, motions that have become necessary as a result of previous successful amending motions) will be allowed at the Technical Committee Report Session.

Consent Documents. Often there are codes and standards up for consideration by the membership that will be noncontroversial and no proper Notices of Intent to Make a Motion will be filed. These "Consent Documents" will bypass the Technical Committee Report Session and head straight to the Standards Council for issuance. The remaining Documents are then forwarded to the Technical Committee Report Session for consideration of the NFPA membership.

Action on Motions at the Technical Committee Report Session. In order to actually make a Certified Amending Motion at the Technical Committee Report Session, the maker of the motion must sign in at least an hour before the session begins. In this way a final list of motions can be set in advance of the session. At the session, each proposed document up for consideration is presented by a motion to adopt the Technical Committee Report on the document. Following each such motion, the presiding officer in charge of the session opens the floor to motions on the document from the final list of Certified Amending Motions followed by any permissible Follow-Up Motions. Debate and voting on each motion proceeds in accordance with NFPA rules. NFPA membership is not required in order to make or speak to a motion, but voting is limited to NFPA members who have joined at least 180 days prior to the session and have registered for the meeting. At the close of debate on each motion, voting takes place, and the motion requires a majority vote to carry. In order to amend a Technical Committee Report, successful amending motions must be confirmed by the responsible Technical Committee, which conducts a written ballot on all successful amending motions following the meeting and prior to the Document being forwarded to the Standards Council for issuance.

Standards Council Issuance

One of the primary responsibilities of the NFPA Standards Council, as the overseer of the NFPA codes and standards development process, is to act as the official issuer of all NFPA codes and standards. When it convenes to issue NFPA documents, it also hears any appeals related to the document. Appeals are an important part of assuring that all NFPA rules have been followed and that due process and fairness have been upheld throughout the codes and standards development process. The Council considers appeals both in writing and through the conduct of hearings at which all interested parties can participate. It decides appeals based on the entire record of the process as well as all submissions on the appeal. After deciding all appeals related to a document before it, the Council, if appropriate, proceeds to issue the document as an official NFPA code or standard. Subject only to limited review by the NFPA Board of Directors, the decision of the Standards Council is final, and the new NFPA code or standard becomes effective twenty days after Standards Council issuance.

Report of the Committee on**Foam****Fay Purvis, Chair**

Vector Fire Technology, Inc., PA [SE]

Jean-Pierre Asselin, FireFlex Systems, Inc., Canada [M]
V. Frank Bateman, Kidde Fire Fighting, CA [M]
Gene E. Benzenberg, Alison Control Inc., NJ [M]
W. D. Cochran, Global F.I.R.E. Response & Safety, TX [SE]
Robert A. Green, Public Service Electric & Gas Company, NJ [U]
 Rep. Edison Electric Institute
Christopher P. Hanauska, Hughes Associates, Inc., MN [SE]
Randall Hendricksen, ChemGuard, Inc., TX [M]
Eldon D. Jackson, The Viking Corporation, MI [M]
 Rep. National Fire Sprinkler Association
Robert Kasiski, FM Global, MA [I]
Eric LaVergne, Williams Fire and Hazard Control, TX [M]
Joan M. Leedy, Dyne Technologies, MN [IM]
Ronald J. Mahlman, The RJA Group, Inc., CA [SE]
Edward C. Norman, Aqueous Foam Technology, Inc., PA [SE]
Keith Olson, Tyco Suppression Systems, WI [M]
David W. Owen, ExxonMobil Corporation, VA [U]
 Rep. American Petroleum Institute
Michael F. Pierson, CSC Advanced Marine, DC [SE]
Niall Ramsden, Resource Protection International, United Kingdom [SE]
Lynn A. Rawls, XL Global Asset Protection Services, MS [I]
Gaston J. Santerre, Integrated Protection Services Inc., CA [IM]
 Rep. American Fire Sprinkler Association
Blake M. Shugarman, Underwriters Laboratories Inc., IL [RT]
Orville M. Slye, Jr., Loss Control Associates, Inc., PA [SE]
John A. Toney, Dooley Tackaberry, Inc., TX [IM] ()
 Rep. National Assn. of Fire Equipment Distributors
Howard L. Vandersall, Lawdon Fire Services, Inc., CA [SE]
Klaus Wahle, US Coast Guard, DC [E]
Kevin D. Westwood, BP International, United Kingdom [U]
Michel Williams, Ultramar Canada, Ltd., Canada [U]
 Rep. NFPA Industrial Fire Protection Section

Alternates

Armand V. Brandao, FM Approvals, MA [I]
 (Alt. to Robert Kasiski)
Arthur R. Dooley, Jr., Dooley Tackaberry, Inc., TX [IM]
 (Alt. to John A. Toney)
Randall Eberly, US Coast Guard, DC [E]
 (Alt. to Klaus Wahle)
Mitchell Hubert, Tyco International/Ansul Inc., WI [M]
 (Alt. to Keith Olson)
William E. Janz, XL Global Asset Protection Services, IL [I]
 (Alt. to Lynn A. Rawls)
George E. Laverick, Underwriters Laboratories Inc., IL [RT]
 (Alt. to Blake M. Shugarman)
Raymond Quenneville, FireFlex Systems, Inc., Canada [M]
 (Alt. to Jean-Pierre Asselin)
Craig L. Redfern, The RJA Group, Inc., FL [SE]
 (Alt. to Ronald J. Mahlman)
Joseph L. Scheffey, Hughes Associates, Inc., MD [SE]
 (Alt. to Christopher P. Hanauska)
Donald H. Seaman, CSC Advanced Marine, DC [SE]
 (Alt. to Michael F. Pierson)
Clark D. Shepard, ExxonMobil Corporation, VA [U]
 (Alt. to David W. Owen)
David M. Sornsins, Nardini Fire Equipment Company, Inc., ND [IM]
 (Alt. to Gaston J. Santerre)
Richard F. Murphy, Cranford, NJ [SE]
 (Member Emeritus)

Staff Liaison: **Timothy A. Hawthorne**

Committee Scope: This Committee shall have primary responsibility for documents on the installation, maintenance, and use of foam systems for fire protection, including foam hose streams.

This list represents the membership at the time the Committee was balloted on the text of this edition. Since that time, changes in the membership may have occurred. A key to classifications is found at the front of this book.

The Report of the Technical Committee on **Foam** is presented for adoption.

This Report was prepared by the **Technical Committee on Foam** and proposes for adoption, amendments to NFPA 11, **Standard for Low-, Medium-, and High-Expansion Foam**, 2005 edition. NFPA 11-2005 is published in Volume 1 of the 2008 National Fire Codes and in separate pamphlet form.

This Report has been submitted to letter ballot of the Technical Committee on Foam, which consists of 27 voting members. The results of the balloting, after circulation of any negative votes, can be found in the report.

 11-1 Log #CP12 **Final Action: Accept**
 (Entire Document)

Submitter: Technical Committee on Foam,

Recommendation: Review entire document to: 1) Update any extracted material by preparing separate proposals to do so, and 2) review and update references to other organizations documents, by preparing proposal(s) as required.

Substantiation: To conform to the NFPA Regulations Governing Committee Projects

Committee Meeting Action: Accept

Number Eligible to Vote: 27

Ballot Results: Affirmative: 23 Abstain: 1

Ballot Not Returned: 3 LaVergne, E., Santerre, G., Williams, M.

Explanation of Abstention:

BENZENBERG, G.: My reasons for Abstaining was that I was not in attendance at the last meeting and did not hear the discussion.

 11-2 Log #1 **Final Action: Accept in Principle**
 (1.1, 1.2, Chapter 3, Chapter 7, 10.2.6.1, 10.2.6.1.1 and 10.6.2.1, Chapter 11)

Submitter: Jean-Pierre Asselin, FireFlex Systems, Inc.

Recommendation: Revise text to read:

This Proposal originates from Tentative Interim Amendment TIA 837 issued by the Standards Council on March 21, 2006.

1. Revise 1.1 and 1.2 as follows:
 - 1.1 *Scope.
 - 1.1.1 This standard covers the design, installation, operation, testing, and maintenance of low-, medium-, and high-expansion, and compressed air foam systems for fire protection.
 - 1.1.2 It is not the intent of this standard to specify where foam protection is required.
 - 1.2 Purpose.
 - 1.2.1 This standard is intended for the use and guidance of those responsible for designing, installing, testing, inspecting, approving, listing, operating, or maintaining fixed, semi-fixed, or portable low-, medium-, and high-expansion, and compressed air foam fire-extinguishing systems for interior or exterior hazards.
 - 1.2.2 Nothing in this standard is intended to restrict new technologies or alternative arrangements, provided the level of safety prescribed by the standard is not lowered.
 2. Add definitions to chapter 3 as follows:
 - 3.3.1 Compressed Air Foam (CAF). A homogenous foam produced by the combination of water, foam concentrate, and air or nitrogen under pressure.
 - 3.3.2 Compressed Air Foam Generating Method. A method of generating compressed air foam recognized in this standard using a mixing chamber to combine air or nitrogen under pressure, water, and foam concentrate in the correct proportions. The resulting compressed air foam is conducted through piping or hoses to the hazard being protected.
 - 3.3.3 Compressed Air Foam Discharge Device. A device specifically designed to discharge compressed air foam in a predetermined pattern.
 - 3.3.4 Compressed Air Foam System (CAFS). A system employing compressed air foam discharge devices or hoses attached to a piping system through which foam is transported from a mixing chamber. Discharge of CAFS begins with automatic actuation of a detection system, or manual actuation that opens valves permitting compressed air foam generated in the mixing chamber, to flow through a piping system and discharged over the area served by the discharge devices or hoses.
 - A. Hazards that Compressed Air Foam Systems are permitted to protect include the following:
 1. Flammable liquids [flash points below 38° C (100° F)] having a vapor pressure not exceeding 276 KPa (40 psia).
 2. Combustible liquids [flash point of 38° C (100° F) and above].
 - B. Compressed Air Foam Systems are not permitted to be used on the following fire hazards:
 1. Polar solvents.
 2. Chemicals, such as cellulose nitrate, that release sufficient oxygen or other oxidizing agents to sustain combustion.
 3. Energized unenclosed electrical equipment.
 4. Water-reactive metals such as sodium, potassium, and NaK (sodium – potassium alloys).
 5. Hazardous water-reactive materials, such as triethyl-aluminum and phosphorous pentoxide.
 6. Liquefied flammable gas.
 3. Add a new 3.3.8.3 Class C as follows:
 - 3.3.8.3 Class C. Fire that involves energized electrical equipment where the electrical resistivity of the extinguishing media is of importance.
 4. Revise current section 7.3.4 as follows:
 - 7.3.4 Plans shall include or be accompanied by the following information, where applicable:
 - (1) Physical details of the hazard, including the location, arrangement, and hazardous materials involved.
 - (2) Type and percentage of foam concentrate.

- (3) Required solution application rate.
 - (4) Water requirements.
 - (5) Calculations specifying required amount of concentrate.
 - (6)* Hydraulic calculations.
 - (7) Calculation specifying required amount of air.
 - (8) CAFS flow calculations report.
 - (9) Identification and capacity of all equipment and devices.
 - (10) Location of piping, detection devices, operating devices, discharge devices, and auxiliary equipment.
 - (11) Schematic wiring diagram.
 - (12) Explanation of any special features.
5. Insert a new Chapter 7 and renumber existing chapters 7 through 11 to chapters 8 through 12 as follows:
 - Chapter 7 Compressed Air Foam Systems
 - 7.1 General.
 - 7.1.1 This chapter shall provide requirements for the correct use of compressed air foam system components.
 - 7.1.2 All components shall be listed for their intended use.
 - 7.1.2.1 Where listings for components do not exist, components shall be approved.
 - 7.2 Water Supplies.
 - 7.2.1 Quality.
 - 7.2.1.1 The water supply to compressed air foam systems shall be permitted to be hard or soft, fresh or salt, but shall be of a quality so that adverse effects on foam formation or foam stability do not occur.
 - 7.2.1.2 No corrosion inhibitors, emulsion breaking chemicals, or any other additives shall be present without prior consultation with the foam concentrate supplier.
 - 7.2.2 Quantity.
 - 7.2.2.1 The water supply shall be of a quantity to supply all the discharge devices and compressed air foam hoses that shall be permitted to be used simultaneously for the specified time.
 - 7.2.2.2 This quantity of water shall include not only the volume required for the compressed air foam apparatus but also water that shall be permitted to be used in other fire fighting operations, in addition to the normal plant requirements.
 - 7.2.3 Pressure. The pressure available at the inlet to the compressed air foam system under required flow conditions shall be at least the minimum pressure for which the system has been designed.
 - 7.2.4 Temperature. Water temperatures shall be between 4°C (40°F) and 37.8°C (100°F).
 - 7.2.5 Design. The water system shall be designed and installed in accordance with NFPA 24, *Standard for the Installation of Private Fire Service Mains and Their Appurtenances*.
 - 7.2.6 Storage. Water supply shall be protected against freezing in climates where freezing temperatures are expected.
 - 7.3 Foam Concentrate.
 - 7.3.1 Quality.
 - 7.3.1.1 Foam concentrate shall be listed.
 - 7.3.1.2 The foam concentrate used in a compressed air foam system shall be that listed for use with the equipment.
 - 7.3.1.2.1 The performance of the system shall be dependent on the composition of the foam concentrate as listed with associated fuels and protection storage arrangement (consult applicable standard for storage arrangement protection).
 - 7.3.1.2.2 The quality of the concentrate for proper performance under the installation requirements of this standard shall be determined by suitable tests.
 - 7.3.2 Quantity. The amount of foam concentrate in the system shall be at least sufficient for the largest single hazard protected, or a group of hazards that are to be protected simultaneously.
 - 7.3.3 Storage Tanks.
 - 7.3.3.1 Storage tanks shall be of corrosion-resisting materials and construction compatible with the foam concentrate.
 - 7.3.3.1.1 Consideration shall be given to design of the storage tanks to minimize evaporation of concentrate.
 - 7.3.3.2 Markings shall be provided on storage tanks to identify the type of concentrate and its intended concentration in solution.
 - 7.3.4 Storage Conditions. Foam concentrate shall be stored within the listed temperature limitations.
 - 7.3.5 Reserve Supply of Foam Concentrate.
 - 7.3.5.1 A reserve supply of foam concentrate sufficient to meet system design requirements shall be provided in order to put the system back into service after operation.
 - 7.3.5.2 The reserve supply shall be in separate tanks or compartments, in drums or cans on the premises, or available from an approved outside source within 24 hours.
 - 7.3.6 Compatibility of Foam Concentrate.
 - 7.3.6.1 Different types of foam concentrates shall not be mixed for storage.
 - 7.3.6.2 Different brands of the same type of concentrate shall not be mixed unless data are provided by the manufacturer to prove that they are compatible and are accepted by the authority having jurisdiction.
 - 7.4 Air Supply.
 - 7.4.1 Quantity.

7.4.1.1 Primary Air Supply. The amount of air shall be at least sufficient for the largest single hazard protected, or a group of hazards that are to be protected simultaneously.

7.4.1.2 Reserve Air Supply. A reserve supply of air sufficient to meet system design requirements shall be provided in order to put the system back into service after operation or available from an approved outside source within 24 hours.

7.4.2 Storage Containers.

7.4.2.1 Storage containers shall be listed.

7.4.2.2 Pressurized storage containers shall be designed to comply with the requirements of the U.S. Department of Transportation or the Canadian Transport Commission.

7.4.2.1.1 Containers shall be designed, fabricated, inspected, certified, and stamped in accordance with Section VIII of ASME Boiler and Pressure Vessel Code.

7.4.2.3 Pressurized storage containers shall not be located where they are subject to severe weather conditions or to mechanical, chemical, or other damage.

7.4.2.4 Each pressurized storage container shall be provided with a releasing device.

7.4.3 Supervision. Air pressure shall be supervised for high and low pressure.

7.4.4 Regulators. Regulators controlling the air pressure for compressed air foam systems shall be listed for the intended purpose.

7.4.5 Plant Air. Plant air shall be permitted to be utilized where the facility has an air supply that complies with the requirements of a dedicated main and reserve air supply, including the quality, quantity, pressure, and reliability requirements of the listing, and shall be subject to the approval of the authority having jurisdiction.

7.4.6 Air Compressor. Air compressors used as a dedicated source of air supply shall be listed for use on fire protection systems.

7.5 Compressed Air Foam Generating Method.

7.5.1 The method used to generate compressed air foam shall be listed.

7.6 Distribution Systems.

7.6.1 Piping.

7.6.1.1 Pipe Materials. Pipe shall be in accordance with Section 4.7.1.

7.6.2 Fittings

7.6.2.1. All pipe fittings shall be in accordance with Section 4.7.3.

7.7 Compressed Air Foam Discharge Devices.

7.7.1 Compressed air foam discharge devices shall be listed for the intended purpose.

7.7.2 Discharge devices shall be located and installed so that they are not subject to mechanical, chemical, climatic, or other conditions that would render them inoperative.

7.8 Operation and Control of Systems.

7.8.1 Operation and control of systems shall be in accordance with Section 4.9

7.9 System Types.

7.9.1 Compressed air foam systems conforming to this chapter shall be fixed deluge-type or fixed spray-type systems, wherein compressed air foam shall discharge simultaneously from all nozzles upon system activation.

7.9.2 The system is permitted to be designed to protect a single or multiple zones.

7.10 Limitations.

7.10.1 Compressed air foam systems shall be designed and installed in accordance with their listing for the specific hazards and protection objectives specified in the listing.

7.10.2 These limitations are described in the manufacturer's listed design manual, which shall be part of the listing of the system.

7.11 System Design. The system shall be designed in accordance with the manufacturer's design manual which shall be part of the listing.

7.12 Installation of Piping and Fittings. Piping for compressed air foam systems shall be installed in accordance with NFPA 13, Standard for the Installation of Sprinkler Systems.

7.13 Installation of Automatic Detection. Automatic detection devices shall be installed in accordance with NFPA 72, *National Fire Alarm Code*.

7.14 CAFS Discharge Device Choice and Location.

7.14.1 Discharge devices shall be of the type listed for the intended purpose.

7.14.2 Discharge devices shall be located in accordance with listing limitations on spacing, floor coverage, and alignment.

7.15 Discharge Density. The design discharge density shall be in accordance with the applicable occupancy standards and in accordance with the manufacturer's listing but in no case less than 1.63 l/min/square meter (0.04 gpm/square foot).

7.15.1 Where fixed spray type systems are used to protect 3 dimensional equipment, the minimum density shall be applied over the projected area of rectangular prism envelope for the equipment and its appurtenances.

7.16 Discharge Duration. The system shall be designed to discharge compressed air foam for a minimum period of 10 minutes over the entire area for deluge-type systems and a minimum of 5 minutes for fixed spray-type systems and shall be in accordance with the manufacturer's listing. Back-up fire sprinkler protection may be applied as required by authority having jurisdiction.

7.17 System Flow Calculation.

7.17.1 General. Compressed air foam flow involves a mixture of both hydraulic and pneumatic elements which shall be addressed together in the

system design to preserve the foam bubble structure until foam is discharged on a hazard.

7.17.2 System flow calculations shall be performed using a calculation method for compressed air foam within the limitations of the manufacturer's design manual.

7.17.3 Compressed air foam piping lengths and configurations of fittings and nozzles shall be in accordance with the manufacturer's listed limitations.

7.18 Plans and Specifications. Plans and specifications shall be in accordance with Chapter 8.

7.19 Testing and Acceptance.

7.19.1 Compressed air foam systems shall be tested in accordance with Chapter 10.

7.20 Maintenance.

7.20.1 Compressed air foam systems shall be maintained in accordance with Chapter 11.

6. Add new sections 10.2.6.1, 10.2.6.1.1, and 10.6.2.1 as follows:

10.2.6.1 All compressed air foam system piping interiors shall be carefully visually examined and, if necessary, cleaned during installation of the pipe.

10.2.6.1.1 Compressed air foam system piping shall be flushed after installation, using the system's air supply in lieu of flushing with water.

10.6.2.1 For Compressed Air Foam Systems, the following data shall be recorded as part of any discharge test:

(1) Static water pressure.

(2) Residual water pressure at the control valve.

(3) System air pressure.

(4) Concentration of the foam solution.

(5) Foam quality (expansion and ¼ drain time) or foam discharge shall be conducted, or the foam discharge shall be visually inspected to ensure that it is satisfactory for the purpose intended (refer to Appendix D of the Standard for Evaluation of foam Concentration Expansion and Drainage Time).

7. Revise Chapter 11 to add following paragraphs: (Existing 11.7 "Operating Instructions and Training" becomes new 11.9.).

11.2.3 Compressed Air Foam Producing Equipment.

11.2.3.1 Compressed air foam generating equipment and accessories shall be inspected annually.

11.2.3.2 Discharge devices shall be visually inspected annually for evidence of mechanical damage.

11.7 High Pressure Cylinders. High pressure cylinders used in compressed air foam systems shall not be recharged without a hydrostatic test (and remarking) if more than 5 years have elapsed from the date of the last test. Cylinders that have been in continuous service without discharging shall be permitted to be retained in service for a maximum of 12 years, after which they shall be discharged and re-tested before being returned to service.

11.8 Operating Instructions and Testing.

11.8.1 Operating and maintenance instructions and layouts shall be posted at control equipment with a second copy on file.

11.8.2 All persons who are expected to inspect, test, maintain, or operate apparatus shall be thoroughly trained and training shall be kept current.

Substantiation: Submitters Reason:

Compressed air foam (CAF) fixed pipe fire suppression systems are a new technology having been brought to market only in the past few months. There are currently no NFPA standards addressing these systems which are substantially different technically from traditional foam systems, currently covered by NFPA 11, and foam-water systems, covered by NFPA 16. In order to enable CAF systems to be listed and accepted for applications in the field, manufacturers certification agencies, regulatory authorities and other users require some form of acknowledgement of these systems in an NFPA standard. The absence of any recognition of CAF systems within NFPA codes and standards is creating a barrier to the technology entering the marketplace.

In October 2003, the NFPA Standards Council directed the subject of CAF systems to the TC on Foam. With that decision in place, this request for a TIA to NFPA 11 for CAF systems is based on the following emergency nature Factors:

In recognition of clause 5-2 (d) of the regulations, this TIA offers the public a benefit that will lessen a recognized hazard. In remote areas or areas with standard water supplies, CAF systems provide a proven means to suppress flammable liquids fires. In these situations, fire suppressions systems would seldom be installed due to the significant cost or local conditions and hence the hazard would not be protected. CAF Systems provide a means to lessen the hazard.

In recognition of clause 5-2(e) of the Regulations, this TIA recognizes an advance in the art of safeguarding property or life where an alternative method is not in use. As indicated in the paragraph immediately above, CAF systems can be installed in low water supply areas where current technology is not being installed. As well, as a result of the significantly reduced water and foam usage, CAF systems can be installed in situations where environmental damage from fire suppressants and the life itself must be minimized.

In recognition of clause 5-2(f) of the Regulations, this TIA will correct a situation in which current NFPA 11 is having an adverse impact on a product. Currently, authorities having Jurisdiction are seeking reference to CAF Systems in some NFPA document as means of ensuring due diligence. Without the TIA, AHJ's can find numerous requirements in NFPA 11 which would not permit CAF Systems to be installed. This TIA permits CAF systems to be installed in those applications fully controlled by the terms of the listing, and thus allows CAF systems to enter the marketplace.

Committee Meeting Action: Accept in Principle

This Proposal originates from Tentative Interim Amendment TIA 837 issued by the Standards Council on March 21, 2006.

1. Revise 1.1 and 1.2 as follows:
 - 1.1 *Scope.
 - 1.1.1 This standard covers the design, installation, operation, testing, and maintenance of low-, medium-, and high-expansion, and compressed air foam systems for fire protection.
 - 1.1.2 It is not the intent of this standard to specify where foam protection is required.
 - 1.2 Purpose.
 - 1.2.1 This standard is intended for the use and guidance of those responsible for designing, installing, testing, inspecting, approving, listing, operating, or maintaining fixed, semi-fixed, or portable low-, medium-, and high-expansion, and compressed air foam fire-extinguishing systems for interior or exterior hazards.
 - 1.2.2 Nothing in this standard is intended to restrict new technologies or alternative arrangements, provided the level of safety prescribed by the standard is not lowered.
2. Add definitions to chapter 3 as follows:
 - 3.3.1 Compressed Air Foam (CAF). A homogenous foam produced by the combination of water, foam concentrate, and air or nitrogen under pressure.
 - 3.3.2 Compressed Air Foam Generating Method. A method of generating compressed air foam recognized in this standard using a mixing chamber to combine air or nitrogen under pressure, water, and foam concentrate in the correct proportions. The resulting compressed air foam is ~~conducted flows~~ through piping or hoses to the hazard being protected.
 - 3.3.3 Compressed Air Foam Discharge Device. A device specifically designed to discharge compressed air foam in a predetermined pattern.
 - 3.3.4 Compressed Air Foam System (CAFS). A system employing compressed air foam discharge devices or hoses attached to a piping system through which foam is transported from a mixing chamber. Discharge of CAFS begins with automatic actuation of a detection system, or manual actuation that opens valves permitting compressed air foam generated in the mixing chamber, to flow through a piping system and discharged over the area served by the discharge devices or hoses.
 - A. Hazards that Compressed Air Foam Systems are permitted to protect include the following:
 1. Flammable liquids ~~as defined in 3.3.9 [flash points below 38° C (100° F)] having a vapor pressure not exceeding 276 KPa (40 psia).~~
 2. Combustible liquids as defined in 3.3.1.1 ~~[flash point of 38° C (100° F) and above];~~
 - B. Compressed Air Foam Systems are not permitted to be used on the following fire hazards:
 1. Polar solvents.
 2. Chemicals, such as cellulose nitrate, that release sufficient oxygen or other oxidizing agents to sustain combustion.
 3. Energized unenclosed electrical equipment.
 4. Water-reactive metals such as sodium, potassium, and NaK (sodium – potassium alloys).
 5. Hazardous water-reactive materials, such as triethyl-aluminum and phosphorous pentoxide.
 6. Liquefied flammable gas.
 3. Add a new 3.3.8.3 Class C as follows:
 - 3.3.8.3 Class C. ~~A Fire~~ that involves energized electrical equipment where the electrical resistivity of the extinguishing media is of importance.
 4. Revise current section 7.3.4 as follows:
 - 7.3.4 Plans shall include or be accompanied by the following information, where applicable:
 - 1) Physical details of the hazard, including the location, arrangement, and hazardous materials involved.
 - 2) Type and percentage of foam concentrate.
 - 3) Required solution application rate.
- ~~4) Submergence volume calculations.~~
- ~~4-5) Water requirements.~~
- ~~5) 6) Calculations specifying required amount of concentrate.~~
- ~~6-7)* Hydraulic calculations.~~
- ~~7) 8) Calculation specifying required amount of air.~~
- ~~8) 9) CAFS flow calculations report.~~
- ~~9-10) Identification and capacity of all equipment and devices.~~
 - ~~10) 1) Location of piping, detection devices, operating devices, discharge devices, and auxiliary equipment.~~
 - ~~11) 2) Schematic wiring diagram.~~
 - ~~12-3) Explanation of any special features.~~
5. Insert a new Chapter 7 and renumber existing chapters 7 through 11 to chapters 8 through 12 as follows:
 - Chapter 7 Compressed Air Foam Systems
 - 7.1 General.
 - 7.1.1 This chapter shall provide requirements for the correct use of compressed air foam system components.
 - 7.1.2 All components shall be listed for their intended use.
 - 7.1.2.1 Where listings for components do not exist, components shall be approved.
 - 7.2 Water Supplies.
 - 7.2.1 Quality.

7.2.1.1 The water supply to compressed air foam systems shall be permitted to be hard or soft, fresh or salt, but shall be of a quality so that adverse effects on foam formation or foam stability do not occur.

7.2.1.2 No corrosion inhibitors, emulsion breaking chemicals, or any other additives shall be present without prior consultation with the foam concentrate supplier.

7.2.2 Quantity.

7.2.2.1 The water supply shall be of a quantity to supply all the discharge devices and compressed air foam hoses that shall be permitted to be used simultaneously for the specified time.

7.2.2.2 This quantity of water shall include not only the volume required for the compressed air foam apparatus but also water that shall be permitted to be used in other fire fighting operations, in addition to the normal plant requirements.

7.2.3 Pressure. The pressure available at the inlet to the compressed air foam system under required flow conditions shall be at least the minimum pressure for which the system has been designed.

7.2.4 Temperature. Water temperatures shall be between 4°C (40°F) and 37.8°C (100°F).

7.2.5 Design. The water system shall be designed and installed in accordance with NFPA 24, *Standard for the Installation of Private Fire Service Mains and Their Appurtenances*.

7.2.6 Storage. Water supply shall be protected against freezing in climates where freezing temperatures are expected.

7.3 Foam Concentrate.

7.3.1 Quality.

7.3.1.1 Foam concentrate shall be listed.

7.3.1.2 The foam concentrate used in a compressed air foam system shall be that listed for use with the equipment.

7.3.1.2.1 The performance of the system shall be dependent on the composition of the foam concentrate as listed with associated fuels and protection storage arrangement (consult applicable standard for storage arrangement protection).

7.3.1.2.2 The quality of the concentrate for proper performance under the installation requirements of this standard shall be determined by suitable tests.

7.3.2 Quantity. The amount of foam concentrate in the system shall be at least sufficient for the largest single hazard protected, or a group of hazards that are to be protected simultaneously.

7.3.3 Storage Tanks.

7.3.3.1 Storage tanks shall be of corrosion-resisting materials and construction compatible with the foam concentrate.

7.3.3.1.1 Consideration shall be given to design of the storage tanks to minimize evaporation of concentrate.

7.3.3.2 Markings shall be provided on storage tanks to identify the type of concentrate and its intended concentration in solution.

7.3.4 Storage Conditions. Foam concentrate shall be stored within the listed temperature limitations.

7.3.5 Reserve Supply of Foam Concentrate.

7.3.5.1 A reserve supply of foam concentrate sufficient to meet system design requirements shall be provided in order to put the system back into service after operation.

7.3.5.2 The reserve supply shall be in separate tanks or compartments, in drums or cans on the premises, or available from an approved outside source within 24 hours.

7.3.6 Compatibility of Foam Concentrate.

7.3.6.1 Different types of foam concentrates shall not be mixed for storage.

7.3.6.2 Different brands of the same type of concentrate shall not be mixed unless data are provided by the manufacturer to prove that they are compatible and are accepted by the authority having jurisdiction.

7.4 Air or Nitrogen Supply.

7.4.1 Quantity.

7.4.1.1 Primary Air Supply. The amount of air or nitrogen shall be at least sufficient for the largest single hazard protected, or a group of hazards that are to be protected simultaneously.

7.4.1.2 Reserve Air Supply. A reserve supply of air or nitrogen sufficient to meet system design requirements shall be provided in order to put the system back into service after operation or available from an approved outside source within 24 hours.

7.4.2 Storage Containers.

7.4.2.1 Storage containers shall be listed.

7.4.2.2 Pressurized storage containers shall be designed to comply with the requirements of the U.S. Department of Transportation or the Canadian Transport Commission.

7.4.2.1.1 Containers shall be designed, fabricated, inspected, certified, and stamped in accordance with Section VIII of ASME Boiler and Pressure Vessel Code.

7.4.2.3 Pressurized storage containers shall not be located where they are subject to severe weather conditions or to mechanical, chemical, or other damage.

7.4.2.4 Each pressurized storage container shall be provided with a releasing device.

7.4.3 Supervision. Air or nitrogen pressure shall be supervised for high and low pressure.

7.4.4 Regulators. Regulators controlling the air or nitrogen pressure for compressed air foam systems shall be listed for the intended purpose.

7.4.5 Plant Air. Plant air shall be permitted to be utilized where the facility has an air supply that complies with the requirements of a dedicated main and reserve air supply, including the quality, quantity, pressure, and reliability requirements of the listing, and shall be subject to the approval of the authority having jurisdiction.

7.4.6 Air Compressor. Air compressors used as a dedicated source of air supply shall be listed for use on fire protection systems.

7.5 Compressed Air Foam Generating Method.

7.5.1 The method used to generate compressed air foam shall be listed.

7.6 Distribution Systems.

7.6.1 Piping.

7.6.1.1 Pipe Materials. Pipe shall be in accordance with Section 4.7.1.

7.6.2 Fittings

7.6.2.1. All pipe fittings shall be in accordance with Section 4.7.3.

7.7 Compressed Air Foam Discharge Devices.

7.7.1 Compressed air foam discharge devices shall be listed for the intended purpose.

7.7.2 Discharge devices shall be located and installed so that they are not subject to mechanical, chemical, climatic, or other conditions that would render them inoperative.

7.8 Operation and Control of Systems.

7.8.1 Operation and control of systems shall be in accordance with Section 4.9

7.9 System Types.

7.9.1 Compressed air foam systems conforming to this chapter shall be fixed deluge-type or fixed spray-type systems, wherein compressed air foam shall discharge simultaneously from all nozzles upon system activation.

7.9.2 The system is permitted to be designed to protect a single or multiple zones.

7.10 Limitations.

7.10.1 Compressed air foam systems shall be designed and installed in accordance with their listing for the specific hazards and protection objectives specified in the listing.

7.10.2 These limitations are described in the manufacturer's listed design manual, which shall be part of the listing of the system.

7.11 System Design. The system shall be designed in accordance with the manufacturer's design manual which shall be part of the listing.

7.12 Installation of Piping and Fittings. Piping for compressed air foam systems shall be installed in accordance with NFPA 13, *Standard for the Installation of Sprinkler Systems*.

7.13 Installation of Automatic Detection. Automatic detection devices shall be installed in accordance with NFPA 72, *National Fire Alarm Code*.

7.14 CAFS Discharge Device Choice and Location.

7.14.1 Discharge devices shall be of the type listed for the intended purpose.

7.14.2 Discharge devices shall be located in accordance with listing limitations on spacing, floor coverage, and alignment.

7.15 Discharge Density. The design discharge density shall be in accordance with the applicable occupancy standards and in accordance with the manufacturer's listing but in no case less than 1.63 l/min/square meter (0.04 gpm/square foot).

7.15.1 Where fixed spray type systems are used to protect 3 dimensional equipment, the minimum density shall be applied over the projected area of rectangular prism envelope for the equipment and its appurtenances.

7.16 Discharge Duration. The system shall be designed to discharge compressed air foam for a minimum period of 10 minutes over the entire area for deluge-type systems and a minimum of 5 minutes for fixed spray-type systems and shall be in accordance with the manufacturer's listing. Back-up fire sprinkler protection may be applied as required by authority having jurisdiction.

7.17 System Flow Calculation.

7.17.1 General. Compressed air foam flow involves a mixture of both hydraulic and pneumatic elements which shall be addressed together in the system design to preserve the foam bubble structure until foam is discharged on a hazard.

7.17.2 System flow calculations shall be performed using a calculation method for compressed air foam within the limitations of the manufacturer's design manual.

7.17.3 Compressed air foam piping lengths and configurations of fittings and nozzles shall be in accordance with the manufacturer's listed limitations.

7.18 Plans and Specifications. Plans and specifications shall be in accordance with Chapter 8.

7.19 Testing and Acceptance.

7.19.1 Compressed air foam systems shall be tested in accordance with Chapter 10.

7.20 Maintenance.

7.20.1 Compressed air foam systems shall be maintained in accordance with Chapter 11.

6. Add new sections 10.2.6.1, 10.2.6.1.1, and 10.6.2.1 as follows:

10.2.6.1 All compressed air foam system piping interiors shall be carefully visually examined and, if necessary, cleaned during installation of the pipe.

10.2.6.1.1 Compressed air foam system piping shall be flushed after installation, using the system's air supply in lieu of flushing with water.

10.6.2.1 For Compressed Air Foam Systems, the following data shall be recorded as part of any discharge test:

(1) Static water pressure.

(2) Residual water pressure at the control valve.

(3) System air pressure.

(4) Concentration of the foam solution.

5) ~~Foam quality (expansion and 1/4 drain time) or foam discharge shall be conducted, or the foam discharge shall be visually inspected to ensure that it is satisfactory for the purpose intended (refer to Appendix D of the Standard for Evaluation of foam Concentration Expansion and Drainage Time).~~

7. Revise Chapter 11 to add following paragraphs: (Existing 11.7 "Operating Instructions and Training" becomes new 11.9.).

11.2.3 Compressed Air Foam Producing Equipment.

11.2.3.1 Compressed air foam generating equipment and accessories shall be inspected annually.

11.2.3.2 Discharge devices shall be visually inspected annually for evidence of mechanical damage.

11.7 High Pressure Cylinders. High pressure cylinders used in compressed air foam systems shall not be recharged without a hydrostatic test (and remarking) if more than 5 years have elapsed from the date of the last test. Cylinders that have been in continuous service without discharging shall be permitted to be retained in service for a maximum of 12 years, after which they shall be discharged and re-tested before being returned to service.

11.8 Operating Instructions and ~~Testing-Training~~.

11.8.1 Operating and maintenance instructions and layouts shall be posted at control equipment with a second copy on file.

11.8.2 All persons who are expected to inspect, test, maintain, or operate apparatus shall be thoroughly trained and training shall be kept current.

Committee Statement: Meets the intent of the submitter.

Number Eligible to Vote: 27

Ballot Results: Affirmative: 22 Negative: 1 Abstain: 1

Ballot Not Returned: 3 LaVergne, E., Santerre, G., Williams, M.

Explanation of Negative:

PURVIS, F.: Paragraph 7.15 of this proposal states that the minimum acceptable discharge density shall be in accordance with the applicable occupancy standards and not less than 1.63 l/min/sq meter or 0.04 gpm/sq ft. This density is based on laboratory scale testing and does not include a safety factor to allow for unforeseen conditions that are experienced in field conditions. Comparable listings for other foam application systems typically incorporate a factor of safety that varies from 1.67 to 2.5 times the test density depending on the application. Although listing agency test data has been submitted to support this very low density it remains to be seen whether the density is adequate for any hazard since there are stated restrictions for application of these systems.

Paragraph 7.16 states that the discharge time shall be 10 minutes for deluge-type and 5 minutes for fixed spray-type systems. However, there is no clear cut definition as to when deluge-type and spray-type are to be used. Furthermore, there is no differentiation in system operating time for type of fuels being protected. It is generally accepted that systems protecting polar solvent fuels normally require longer discharge times than those for hydrocarbons.

A general comment applying to the new chapter concerns the listed foams for various applications involving this system. The FM Global support documentation indicates that the listed foam concentrates will be used at injection percentages that deviate from those published by the manufacturers. In the case of hydrocarbon liquids the injection rate is lower but in the case of polar solvents the injection rate is higher. This will create confusion for users and service technicians who will likely be guided by the markings on the foam containers and/or the manufacturer's product data sheets.

Explanation of Abstention:

BENZENBERG, G.: My reasons for Abstaining was that I was not in attendance at the last meeting and did not hear the discussion.

11-3 Log #CP13 **Final Action: Accept**
(1.2.3 (New))

Submitter: Technical Committee on Foam,
Recommendation: Add a new section to read as follows:

1.2.3 Low, medium and high expansion foam systems are intended to provide property protection and not life safety.

Substantiation: Exclusion of life safety in the standard is needed.

Committee Meeting Action: Accept

Number Eligible to Vote: 27

Ballot Results: Affirmative: 23 Abstain: 1

Ballot Not Returned: 3 LaVergne, E., Santerre, G., Williams, M.

Explanation of Abstention:

BENZENBERG, G.: My reasons for Abstaining was that I was not in attendance at the last meeting and did not hear the discussion.

11-4 Log #18 **Final Action: Accept**
(3.3.1.1 Combustible Liquid Classification)

Submitter: Glossary of Terms Technical Advisory Committee,

Recommendation: Revise text as follows:

3.3.1.1 Combustible Liquid Classification.

3.3.1.1.1 Combustible Liquid Class II. Any A liquid that has a closed-cup flash point at or above 37.8°C (100°F) and below 60°C (140°F). [30, 2003]

3.3.1.1.2 Combustible Liquid Class IIIA. Any A liquid that has a closed-cup flash point at or above 60°C (140°F), but below 93°C (200°F). [30, 2003]

3.3.1.1.3 ~~Combustible Liquid Class IIIB.~~ Any A liquid that has a closed-cup flash point at or above 93°C (200°F). [30, 2003]

Substantiation: This proposal is intended to generate consistent definitions and minimize the number of duplicate definitions in the NFPA Glossary of Terms in accordance with the scope of the NFPA Glossary of Terms Technical Advisory Committee.

Since definitions are normally written as singular, “Any” was changed to “A” which also correlates with 3.3.1

Thirty-three NFPA standards include the definition of “combustible liquid” and all of them use the same technical criteria to define the various terms and Classes. Proposals are being submitted to the other Technical Committees requesting adoption of a common consistent definition that does not, in any way, change the flash points of the various Classes of Liquids. They merely change the grammar, the sequence of the text, or are editorial.

Committee Meeting Action: Accept

Number Eligible to Vote: 27

Ballot Results: Affirmative: 24

Ballot Not Returned: 3 LaVergne, E., Santerre, G., Williams, M.

11-5 Log #7 **Final Action: Accept**
(3.3.4 Compressed Air Foam Systems)

Submitter: Raymond Quenneville, FireFlex Systems, Inc.

Recommendation: Revise text to read as follows:

B. Compressed Air Foam Systems are not permitted to be used on the following fire hazards:

1. ~~Polar Solvents:~~

Renumber other items.

Substantiation: Additional testing has been conducted to extend the listing of the technology for Polar Solvent applications. The enclosed FM Approval report 3026593 is provided as supporting document for the above proposal.

Note: Supporting material is available for review at NFPA Headquarters.

Committee Meeting Action: Accept

Number Eligible to Vote: 27

Ballot Results: Affirmative: 23 Abstain: 1

Ballot Not Returned: 3 LaVergne, E., Santerre, G., Williams, M.

Explanation of Abstention:

BENZENBERG, G.: My reasons for Abstaining was that I was not in attendance at the last meeting and did not hear the discussion.

11-6 Log #19 **Final Action: Accept**
(3.3.8.1 Class A)

Submitter: Glossary of Terms Technical Advisory Committee,

Recommendation: Revise text as follows:

3.3.8.1 *Class A.* A fire Fire in ordinary combustible materials, such as wood, cloth, paper, rubber, and many plastics. [10:3.3]

Substantiation: The proposed revised definition correlates with the preferred definition in the NFPA Glossary of Terms that is used in eight NFPA standards (1, 10, 11, 16, 18, 1901, 1906, and 2001).

This proposal is submitted in accordance with the scope of the NFPA Glossary of Terms Advisory Committee that the Committee is responsible for “Submitting proposals and comments to NFPA documents to generate consistent definitions and minimize the number of duplicate definitions.”

Committee Meeting Action: Accept

Number Eligible to Vote: 27

Ballot Results: Affirmative: 24

Ballot Not Returned: 3 LaVergne, E., Santerre, G., Williams, M.

11-7 Log #20 **Final Action: Accept**
(3.3.8.2 Class B)

Submitter: Glossary of Terms Technical Advisory Committee,

Recommendation: Revise text as follows:

3.3.8.2 *Class B.* A fire Fires in flammable liquids, combustible liquids, petroleum greases, tars, oils, oil-based paints, solvents, lacquers, alcohols, and flammable gases.

Substantiation: A definition is normally written as singular.

The proposed revised definition correlates with the preferred definition in the NFPA Glossary of Terms.

This proposal is submitted in accordance with the scope of the NFPA Glossary of Terms Advisory Committee that the Committee is responsible for “Submitting proposals and comments to NFPA documents to generate consistent definitions and minimize the number of duplicate definitions.”

Committee Meeting Action: Accept

Number Eligible to Vote: 27

Ballot Results: Affirmative: 24

Ballot Not Returned: 3 LaVergne, E., Santerre, G., Williams, M.

11-8 Log #21 **Final Action: Accept**
(3.3.9 Flammable Liquid)

Submitter: Glossary of Terms Technical Advisory Committee,

Recommendation: Revise 3.3.9 as shown:

3.3.9 Flammable Liquid. A liquid that has a closed-cup flash point that is below 37.8°C (100°F) and a maximum vapor pressure of ~~2068~~ 2068.6 mm Hg (40 psia) at 37.8°C (100°F). [30, 2003]

3.3.9.1 Flammable Liquid Classification.

3.3.9.1.1 Flammable-Liquid Class I. Any A liquid that has a closed-cup flash point below 37.8°C (100°F) and a Reid vapor pressure not exceeding 2068.6 mm Hg (40 psia) at 37.8°C (100°F). [30, 2003]

3.3.9.1.2 Flammable-Liquid-Class IA. Any A liquid that has a closed-cup flash point below 22.8°C (73°F) and a boiling point below 37.8°C (100°F). [30, 2003]

3.3.9.1.3 Flammable-Liquid-Class IB. Any A liquid that has a closed-cup flash point below 22.8°C (73°F) and a boiling point at or above 37.8°C (100°F). [30, 2003]

3.3.9.1.4 Flammable-Liquid Class IC. Any A liquid that has a closed-cup flash point at or above 22.8°C (73°F) but below 37.8°C (100°F). [30, 2003]

Substantiation: This proposal is intended to generate consistent definitions and minimize the number of duplicate definitions in the NFPA Glossary of Terms in accordance with the scope of the NFPA Glossary of Terms Technical Advisory Committee.

Since definitions are normally written as singular, “Any” was changed to “A” which also correlates with 3.3.9. The addition of “closed-cup” provides consistency in all the definitions.

The deletion of the word “Reid” in 3.3.9.1.1 was made to comply with 2.3.2.4 of the NFPA Manual of Style which states “References to other documents or sections of a document, notes, lists, footnotes, cautions, warnings, or figures shall not be permitted in definitions.”

Thirty-eight NFPA standards include variations for the definition of “flammable liquid” and almost all of them are basically the same. Acceptance of this revision will not change any of the technical parameters. It will consolidate 16 definitions of flammable liquid and nine Class definitions into one definition for flammable liquid and four Class definitions. It will present consistent terminology in a standardized format that complies with the NFPA Manual of Style.

Proposals are being submitted to the other Technical Committees requesting adoption of the common consistent definition that does not, in any way, change the flash points or vapor pressure of the various Classes of Liquids. They merely change the grammar, the sequence of the text, or are editorial.

Committee Meeting Action: Accept

Number Eligible to Vote: 27

Ballot Results: Affirmative: 24

Ballot Not Returned: 3 LaVergne, E., Santerre, G., Williams, M.

11-9 Log #CP15 **Final Action: Accept**
(3.3.10 and 4.4.1.3)

Submitter: Technical Committee on Foam,

Recommendation: Revise Sections 3.3.10 and 4.4.1.3 to read as follows:

3.3.10 Foam. A stable aggregation of small bubbles of lower density than oil or water that exhibits tenacity for covering horizontal surfaces.

4.4.1.3 Low-expansion foams generated separately from protein, fluoroprotein, FFFP, AFFF, and alcohol resistant concentrates shall be permitted to be applied to a fire in sequence or simultaneously.

Substantiation: Better defines the term foam.

Committee Meeting Action: Accept

Number Eligible to Vote: 27

Ballot Results: Affirmative: 24

Ballot Not Returned: 3 LaVergne, E., Santerre, G., Williams, M.

11-10 Log #8 **Final Action: Accept in Principle**
(3.3.12.2 Aqueous Film-Forming Foam Concentrate (AFFF))

Submitter: Joan M. Leedy, Dyne Technologies

Recommendation: Add new text as follows:

A concentrate based on fluorinated surfactants plus foam stabilizers to produce a fluid aqueous film for suppressing hydrocarbon fuel vapors and usually diluted with water to a 1 percent, 3 percent, or 6 percent solution.

Substantiation: The current definition does not define the ability of AFFFs to form a film on liquid hydrocarbons. By adding this statement it defines film forming in the same way it is defined for FFFPs.

Committee Meeting Action: Accept in Principle

Add new text as follows:

A concentrate based on fluorinated surfactants plus foam stabilizers to produce a fluid aqueous film for suppressing hydrocarbon fuel vapors and usually diluted with water to a 1 percent, 3 percent, or 6 percent solution.

Committee Statement: Editorial.

Number Eligible to Vote: 27

Ballot Results: Affirmative: 24

Ballot Not Returned: 3 LaVergne, E., Santerre, G., Williams, M.

11-11 Log #CP17 **Final Action: Accept**
(3.3.12.3)

Submitter: Technical Committee on Foam,
Recommendation: Revise Section 3.3.12.3 to read as follows:
3.3.12.3* **Fluoroprotein Foam Concentrate.** A concentrate very similar to protein-foam concentrate but with a synthetic fluorinated surfactant additive.
3.3.12.4~~3.1~~* **Film-Forming Fluoroprotein Foam Concentrate (FFFP).** A concentrate that uses fluorinated surfactants to produce a fluid aqueous film for suppressing hydrocarbon fuel vapors.
A.3.3.12.3 **Fluoroprotein Foam Concentrate.** In addition to an air-excluding foam blanket, this concentrate also can deposit a vaporization-preventing film on the surface of a liquid fuel. It is diluted with water to form 3 percent to 6 percent solutions depending on the type. This concentrate is compatible with certain dry chemicals.

This type of foam utilizes a protein base plus stabilizing additives and inhibitors to protect against freezing, corrosion, and bacterial decomposition, and it also resists fuel pickup. The foam is usually diluted with water to a 3 percent or 6 percent solution and is dry chemical compatible.

A.3.3.12.4~~3.1~~* **Film-Forming Fluoroprotein Foam Concentrate (FFFP).** In addition to an air-excluding foam blanket, this concentrate also can deposit a vaporization-preventing film on the surface of a liquid fuel. It is diluted with water to form 3 percent to 6 percent solutions depending on the type. This concentrate is compatible with certain dry chemicals. This type of foam utilizes a protein base plus stabilizing additives and inhibitors to protect against freezing, corrosion, and bacterial decomposition, and it also resists fuel pickup. The foam is usually diluted with water to a 3 percent or 6 percent solution and is dry chemical compatible.

Substantiation: Editorial.
Committee Meeting Action: Accept
Number Eligible to Vote: 27
Ballot Results: Affirmative: 24
Ballot Not Returned: 3 LaVergne, E., Santerre, G., Williams, M.

11-12 Log #CP14 **Final Action: Accept**
(3.3.12.3.1)

Submitter: Technical Committee on Foam,
Recommendation: Revise Section 3.3.12.3.1 to read as follows:
3.3.12.3.1* **Film-Forming Fluoroprotein Foam Concentrate (FFFP).** A protein-foam concentrate that uses fluorinated surfactants to produce a fluid aqueous film for suppressing hydrocarbon fuel vapors.
Substantiation: Better defines FFFP.
Committee Meeting Action: Accept
Number Eligible to Vote: 27
Ballot Results: Affirmative: 24
Ballot Not Returned: 3 LaVergne, E., Santerre, G., Williams, M.

11-13 Log #9 **Final Action: Accept in Principle**
(3.3.12.4 Film-Forming Foam (New))

Submitter: Joan M. Leedy, Dyne Technologies
Recommendation: Add new text as follows:
3.3.12.4 **Film Forming Foam** – A concentrate that when mixed at its nominal use concentration, will form an aqueous film on hydrocarbon fuels, specifically cyclohexane.
Substantiation: The problem is that no where in the document is film formation defined. Underwriters Laboratories 162 requires a positive spreading coefficient on cyclohexane and section 4.3.1.1 requires a foam to be listed. This does not change the requirement for a foam but makes it clearer to the user.

Committee Meeting Action: Accept in Principle
Revise proposed new text as follows:
3.3.12.4 **Film Forming Foam** – A concentrate that when mixed at its nominal use concentration, will form an aqueous film on hydrocarbon fuels. The hydrocarbon fuel typically used as a minimum benchmark for film formation is cyclohexane.
Committee Statement: It is not the intent of the committee to limit the formation of film on cyclohexane only.
Number Eligible to Vote: 27
Ballot Results: Affirmative: 24
Ballot Not Returned: 3 LaVergne, E., Santerre, G., Williams, M.

11-14 Log #11 **Final Action: Accept in Principle**
(3.3.25.1)

Submitter: Eldon D. Jackson, The Viking Corporation
Recommendation: Revise text as follows:
3.3.25.1 * **In-line Balanced Pressure Proportioning** A foam proportioning system utilizing a foam concentrate pump or a bladder tank and listed system pressure reducing valve at all design flow rates, the constant foam concentrate pressure of which is greater than the maximum water pressure under all operating conditions.

Substantiation: ILBP system includes the bladder tank system with listed pressure regulating valve. Figure A.3.3.25.1.1(b) was included but no description in text.

Committee Meeting Action: Accept in Principle
Revise text as follows:
3.3.25.1.1 * **In-line Balanced Pressure Proportioning.** A foam proportioning system utilizing a foam concentrate pump or a bladder tank in conjunction with a listed pressure reducing valve. At all design flow rates, the constant foam concentrate pressure is greater than the maximum water pressure at the inlet to the in-line balanced pressure proportioner. A pressure balancing valve integral to the in-line balanced pressure proportioner regulates the foam concentrate pressure to be balanced to incoming water pressure.
Committee Statement: Meets the intent of the submitter.
Number Eligible to Vote: 27
Ballot Results: Affirmative: 24
Ballot Not Returned: 3 LaVergne, E., Santerre, G., Williams, M.

11-15 Log #CP8 **Final Action: Accept**
(4.2.1.2.1, 4.2.1.3, 4.3.2.1.3, 4.3.2.2, 4.3.2.5.2.2, 4.3.2.6, 4.6.3, 4.6.4, 4.7.4.3, 4.7.6.5, 4.9.2.7)

Submitter: Technical Committee on Foam,
Recommendation: Revise the following Sections to read as follows:
4.2.1.2.1 This quantity shall include not only the volume required for the foam apparatus but also water that can be permitted to be used in other fire-fighting operations, in addition to the normal plant requirements.
4.2.1.3 **Pressure.** The pressure available at the inlet to the foam system (e.g., foam generator, air foam maker) under required flow conditions shall be at least the minimum pressure for which the system has been designed.
4.3.2.1.3 For outdoor nonautomatic systems, the AHJ shall be permitted to approve the storage of foam concentrate in a location off premises where these supplies are available at all times.
4.3.2.2* **Quantity.** The amount of concentrate shall meet the discharge requirements be at least sufficient for the largest single hazard protected or group of hazards that are to be protected simultaneously.
4.3.2.5.2.2 The reserve supply shall be in separate tanks or compartments, in drums or cans on the premises, or available shall be able to be obtained from an approved outside source within 24 hours.
4.3.2.6 **Auxiliary Supplies.** Other equipment necessary to recommission the system, such as bottles of nitrogen or carbon dioxide for premix systems, also shall be able to be secured available.
4.6.3 **F**foam concentrate pumps shall have adequate the capacities to meet the maximum system demand.
4.6.4 To ensure positive injection of concentrates, the discharge pressure ratings of pumps at the design discharge capacity shall be in excess of the maximum water pressure available under any condition at the point of concentration injection.
4.7.4.3* **Welding practices** shall conform to the requirements of AWS D10.9.
4.7.6.5 All valves required for automatic foam systems shall be supervised in their normal operating position by one of the following methods:
(1) Electrical, in accordance with NFPA 72
(2) Locked
(3) Sealed
4.9.2.7 In some cases, it The system shall be permitted to be arranged the system to shut off automatically after a predetermined operating time.
Substantiation: Removes unenforceable language as per the NFPA Manual of Style.
Committee Meeting Action: Accept
Number Eligible to Vote: 27
Ballot Results: Affirmative: 24
Ballot Not Returned: 3 LaVergne, E., Santerre, G., Williams, M.

11-16 Log #12 **Final Action: Reject**
(4.2.1.2.2.1 (New))

Submitter: Eldon D. Jackson, The Viking Corporation
Recommendation: Add new text as follows:
4.2.1.2.2.1 **Premix systems shall be tested for effectiveness and replenished due to manufacturer's recommendation as premix solutions can diminish in effectiveness over short period of time.**
Substantiation: Premix solutions lose their effectiveness over time and the manufacturer should be consulted or testing done to measure the quality of the premix solution at least annually or per the manufacturer's recommendation. End users should be made aware of this potential problem.
Committee Meeting Action: Reject
Committee Statement: Already covered in Chapter 11.
Number Eligible to Vote: 27
Ballot Results: Affirmative: 24
Ballot Not Returned: 3 LaVergne, E., Santerre, G., Williams, M.

11-17 Log #13
(4.5.1 (New))**Final Action: Accept in Principle****Submitter:** Eldon D. Jackson, The Viking Corporation**Recommendation:** Add new text as follows:

4.5.1 The proportioning system shall meet the listed minimum flow rate based on the minimum and maximum system discharge flow rate. Some alcohol resistant foam Proportioners require much higher flow rates to meet the minimum flow and proper proportioning percentage of the foam concentrate being used. In Balanced pressure systems when the flow is less than the listed minimum the foam percentage is less than the required where a smaller proportioner shall be applied or use an inline Balanced Pressure proportioning system which when the flow rate is below the minimum listed flow rate the percentage is greater than the design percentage of the foam concentrate.

Substantiation: If system proportioning is designed for the maximum possible flow rate and some place in the protected area requires a flow rate below the minimum listed flow rate of the proportioning system the proper percentage of foam solution will not be obtainable and render the system inoperable. This can occur in Alcohol resistant foam concentrates which are very viscous and typically require much higher minimum flow rates to meet the -0% to + 30% requirement. The type of system to proportion foam or the size of the proportioner must be adjusted.

Committee Meeting Action: Accept in Principle

Add new text as follows:

4.5.1* The proportioning system shall meet the listed minimum flow rate based on the minimum and maximum system discharge flow rate.

A.4.5.1 Some alcohol resistant foam proportioners require much higher flow rates to meet the minimum flow and proper proportioning percentage of the foam concentrate being used. In Balanced pressure systems when the flow is less than the listed minimum the foam percentage is less than the required where a smaller proportioner should be applied or use an inline Balanced Pressure proportioning system which when the flow rate is below the minimum listed flow rate the percentage is greater than the design percentage of the foam concentrate.

Committee Statement: The proposed language after the first sentence is not mandatory but is useful as annex material.

Number Eligible to Vote: 27**Ballot Results:** Affirmative: 24**Ballot Not Returned:** 3 LaVergne, E., Santerre, G., Williams, M.11-18 Log #14
(4.7.2.1)**Final Action: Reject****Submitter:** Eldon D. Jackson, The Viking Corporation**Recommendation:** Revise text as follows:

4.7.2.1 * Galvanized threaded pipe shall be used for non corrosive atmospheres. Where fabrication by welding is performed the area effected shall be coated with corrosion resistant coating compatible with galvanizing. Where welding fabrication is applied black steel pipe can be used and allowance for C Value shall be applied as described in 4.7.2.5.

Substantiation: As galvanized pipe and fittings are required many use black steel pipe when fabrication by welding is required. Also in section 4.7.2.5 we allow friction loss calculation when black pipe is applied. Also when requiring galvanized pipe we should recommend repair of the galvanizing when fabrication is performed or spot corrosion will occur. We should allow and describe normal practice being applied.

Committee Meeting Action: Reject**Committee Statement:** The committee concluded that galvanizing is required.**Number Eligible to Vote: 27****Ballot Results:** Affirmative: 24**Ballot Not Returned:** 3 LaVergne, E., Santerre, G., Williams, M.11-19 Log #CP18
(4.7.2.1 and 4.7.3.5)**Final Action: Accept****Submitter:** Technical Committee on Foam,**Recommendation:** Revise Section 4.7.2.1 and 4.7.3.5 to read as follows:

4.7.2.1* Galvanized pipe shall be used for noncorrosive atmospheres.

4.7.3.5* Galvanized fittings shall be used for noncorrosive atmospheres.

4.7.2.5 For the purpose of computing friction loss in foam solution piping, the following C-values shall be used for the Hazen-Williams formula:

(1) Black steel or unlined cast iron pipe — 100

—(2) Galvanized steel pipe — 120

(2) Other C-values for corrosion resistant piping materials in accordance with NFPA 13.

—(3) Asbestos-cement or cement-lined cast iron pipe — 140

Substantiation: It is the intent to require the use of galvanized pipe and fittings for all system piping except foam concentrate lines.

Committee Meeting Action: Accept**Number Eligible to Vote: 27****Ballot Results:** Affirmative: 24**Ballot Not Returned:** 3 LaVergne, E., Santerre, G., Williams, M.11-20 Log #2
(4.7.3.4)**Final Action: Reject****Submitter:** David Spencer, Shell Pipeline Company LP**Recommendation: Statement Problem:**

The installation of semi-fixed or fixed storage tank foam systems utilizing galvanized pipe and fittings in accordance with NFPA-11 piping requirements presents difficult technical challenges. The difficulty increases as the tank diameter increases.

This is especially true for floating roof tank foam system piping, which is typically pre-bent to match the storage tank circumference. The piping sections are sent to the site along with the appropriate weld fittings and then fabricated on site utilizing field welding processes.

The galvanized piping and fitting requirement normally forces the installation contractor to complete the system pre-fitting and fabrication prior to the system components being galvanized. To assure integrity of the galvanizing, completed welded piping segments are sent off site for galvanizing. When the galvanizing process is complete the piping is returned to the site for final installation onto the tank.

Galvanized piping installation leaves the installer with very little latitude for dealing with field corrections, changes, additions, or deletions to the system. If these are required the contractor is forced to get the items galvanized again to assure the integrity of the galvanizing process.

Additional safety and environmental issues arise with this system. The need to double handle the piping, at elevated heights, if revisions are needed. The exposure to the galvanized coating during removal for welding and to the atmosphere are of great concern to the contractor's employees.

Due to the complexities related to galvanized foam solution line installation some users may choose to use piping, which does not meet NFPA 11 requirements. In other cases foam systems are simply not being installed on existing storage tanks due to the lack of adequate lead time to work out all of the installation issues related to galvanized piping.

Statement of Proposed Solution to Problem Stated:

Installation of galvanized foam solution piping could be dramatically simplified and improved by the use of grooved fittings that can withstand high temperature and exposure to fire with no serious loss in performance. New technology has resulted in grooved fittings with specially designed elastomeric/metal seals that can withstand flammable liquid fire exposure while still providing the integrity of the piping joint.

The use of grooved pipe and fittings for installations of these types using high temperature rated elastomeric/metal gaskets would result in the following:

- Foam solution piping could be fabricated and installed with much less complication and cost.
- Piping sections could be pre-fabricated and galvanized before being sent to the job site.
- System changes, i.e., pipe length adjustment, addition, or deletion of fittings could be accommodated easily on site.
- Galvanized grooved pipe, fittings, and grooved couplings are readily available with high temperature gaskets to meet this application needs.
- Labor expenditures would be greatly reduced since the site prefabrication and installation would only occur once and not twice as currently required in many instances.
- Overall installation time for system attachment to the storage tank would be significantly reduced due to the relative ease one uses to mechanically combine a pre-engineered system configured of grooved piping, couplings and fittings constituting a new tank foam system.
- Mechanization for installation and transportation costs would not have to be duplicated.
- Piping system components can be easily reconfigured to accommodate larger flows that may be required as a result of future stored product changes.
- More foam system installations since cost and installation times could be reduced.
- The Health and Safety impact to the installer would be greatly decreased.

Substantiation: The above statement of proposed solution is not meant to preclude the use of threaded pipe and fittings as an additional means of joining galvanized pipe. However, due to the average pipe sizes used in these hazards and the difficulty associated with fabricating and installing large size threaded pipe (resulting in excessive labor costs), threaded piping is not addressed in the above solution but certainly could be included.

Committee Meeting Action: Reject**Committee Statement:** See Committee Action and Statement on Proposal 11-22 (Log #4).**Number Eligible to Vote: 27****Ballot Results:** Affirmative: 24**Ballot Not Returned:** 3 LaVergne, E., Santerre, G., Williams, M.11-21 Log #3
(4.7.3.4)**Final Action: Accept in Principle****Submitter:** David Spencer, Shell Pipeline Company LP**Recommendation:** Revise text to read as follows:

4.7.3.4 Rubber or elastomeric fittings shall not can be used in fire exposed areas unless the foam system is automatically constructed only if high temperature rated, extra heavy duty grooved fittings and gaskets have been

tested in accordance with API 607 standards and meets this criteria within industry standards. System shall be permitted to be activated manually or automatically.

Substantiation: See accompanying documentation and test report for "Statement of Problem Substantiation for Proposal".

Note: Supporting material is available for review at NFPA Headquarters.

Committee Meeting Action: Accept in Principle

Committee Statement: See Committee Action and Statement on Proposal 11-22 (Log #4).

Number Eligible to Vote: 27

Ballot Results: Affirmative: 24

Ballot Not Returned: 3 LaVergne, E., Santerre, G., Williams, M.

11-22 Log #4
(4.7.3.4)

Final Action: Accept in Principle

NOTE: This Proposal originates from Tentative Interim Amendment TIA 889 issued by the Standards Council on October 4, 2007.

Submitter: David Spencer, Shell Pipeline Company LP

Recommendation: Revise 4.7.3.4 to read as follows:

4.7.3.4 Rubber or elastomeric-gasketed fittings shall not be used in fire-exposed areas hazards unless the foam system is automatically actuated, or test data is submitted to show acceptable performance under fire conditions within a fire exposed hazard.

Substantiation: Problem noted as provided within additional data as shown.

The installation of semi-fixed or fixed storage tanks foam systems utilizing galvanized pipe and fittings in accordance with NFPA 11 piping requirements presents difficult technical challenges. The difficulty increases as the tank diameter increases.

This is especially true for floating roof tank foam system piping, which is typically pre-bent to match the storage tank circumference. The piping sections are sent to the site along with the appropriate weld fittings and then fabricated on site utilizing field welding processes.

The galvanized piping and fitting requirement normally forces the installation contractor to complete the system pre-fitting and fabrication prior to the system components being galvanized. To assure integrity of the galvanizing, completed welded piping segments are sent off site for galvanizing. When the galvanizing process is complete the piping is returned to the site to for final installation onto the tank.

Galvanized piping installation leaves the installer with very little latitude for dealing with field corrections, changes, additions, or deletions to the system. If these are required the contractor is forced to get the items galvanized again to assure the integrity of the galvanizing process.

Additional safety and environmental issue's arise with this system. The need to double handle the piping, at elevated heights, if revisions are needed. The exposure to the galvanized coating during removal for welding and to the atmosphere are of great concern to the contractors employee's.

Due to the complexities related to galvanized foam solution line installation some users may choose to use piping, which does not meet NFPA 11 requirements. In other cases foam systems are simply not being installed on existing storage tanks due to the lack of adequate lead time to work out all of the installation issues related to galvanized piping.

Statement of Proposed Solution to Problem Stated:

Installation of galvanized foam solution piping could be dramatically simplified and improved by the use of grooved fittings that can withstand high temperature and exposure to fire with no serious loss in performance. New technology has resulted in grooved fittings with specially designed elastomeric/metal seals that can withstand flammable liquid fire exposure while still providing the integrity of the piping joint.

The use of grooved pipe and fittings for installations of these types using high temperature rated elastomeric/metal gaskets would result in the following:

- Foam solution piping could be fabricated and installed with much less complication and cost.
- Piping sections could be pre-fabricated and galvanized before being sent to the job site.
- System changes i.e. pipe length adjustment, addition, or deletion of fittings could be accommodated easily on site.
- Galvanized grooved pipe, fittings, and grooved couplings are readily available with high temperature gaskets to meet this application needs.
- Labor expenditures would be greatly reduced since the site prefabrication and installation would only occur once and not twice as currently required in many instances.
- Overall installation time for system attachment to the storage tanks would be significantly reduced due to the relative ease one uses to mechanically combine a pre-engineered system configured of grooved piping, couplings and fittings constituting a new tank foam system.
- Mechanization for installation and transportation costs would not have to be duplicated.
- Piping system components can be easily reconfigured to accommodate larger flows that may be required as a result of future stored product changes.
- More foam system installations since cost and installation times could be reduced.

Note: The above statement of proposed solution is not meant to preclude the use of threaded pipe and fittings as an additional means of joining galvanized pipe. However, due to the average pipe sizes used in these hazards and the

difficulty associated with fabricating and installing large size threaded pipe (resulting in excessive labor costs), threaded piping is not addressed in the above solution but certainly could be included.

We submit the following data for grooved piping systems for consideration with the above statement of proposed solution:

- "Fire Testing for Grooved Piping Systems" by B.H. Patterson, SPE, Chevron U.S.A. Inc. Journal of Petroleum Technology, August 1988.
- HP-70ES Coupling with FIRE-R Gasket. "Tested to API 607 Fire Exposure Standards." Victaulic Material Specifications.

Note: Supporting material is available for review at NFPA Headquarters.

Committee Meeting Action: Accept in Principle

Revise Section 4.7.3.4 to read as follows:

4.7.3.4 listed rubber or elastomeric-gasketed fittings shall be permitted to be used in fire-exposed areas if the foam system is automatically actuated.

4.7.3.4.1 Listed rubber or elastomeric-gasketed fittings shall be permitted to be used in fire-exposed areas if the foam system is manually actuated and high temperature rated extra heavy duty grooved fittings and gaskets have been tested in accordance with API 607 Standards and meet this criteria within industry standards.

Committee Statement: Addresses both manual and automatic operation.

Number Eligible to Vote: 27

Ballot Results: Affirmative: 24

Ballot Not Returned: 3 LaVergne, E., Santerre, G., Williams, M.

11-23 Log #15
(4.7.3.5)

Final Action: Reject

Submitter: Eldon D. Jackson, The Viking Corporation

Recommendation: Revise text as follows:

4.7.3.5* Galvanized threaded fittings shall be used for non corrosive atmospheres or black steel welded fittings when fabrication by welding shall be allowed.

Substantiation: Galvanized fittings are very difficult to obtain when welding fabrication required, we should allow common practice that is being applied.

Committee Meeting Action: Reject

Committee Statement: At the request of the submitter.

Number Eligible to Vote: 27

Ballot Results: Affirmative: 24

Ballot Not Returned: 3 LaVergne, E., Santerre, G., Williams, M.

11-24 Log #CP9

Final Action: Accept

(5.2.5.1.2.2, 5.9.2.2, 5.2.6.2.5, 5.3.5.4.6, 5.2.4.4, 5.3.1, 5.4.1, 5.4.2, 5.7.3.4.2, 5.7.3.5.4.1, 5.3.5.2.2, 5.6.3, 5.2.4.1.1, 5.4.2, 5.4.2.2.1, 5.4.2.3.1, 5.6.2, 5.7.3.4.2, 5.7.3.5.4.1, A.5.8.1)

Submitter: Technical Committee on Foam,

Recommendation: Revise the following Sections to read as follows:

eans of protection for fixed-roof tanks over 18 m (60 ft) in diameter.

Revise the following Sections to read as follows:

5.2.4.1.1 Monitor nozzles shall not be considered used as the primary means of protection for fixed-roof tanks over 18 m (60 ft) in diameter.

5.2.4.4 Design Parameters. Where monitors and handline nozzles are used to protect tanks containing flammable and combustible liquids requiring alcohol-resistant foams, the operation time shall be 65 minutes at listed application rates, unless the foam manufacturer has established, by fire test, that a shorter time can shall be permitted.

5.2.5.1.2.2 Each outlet shall be sized to deliver foam at approximately the same minimum application rate or higher.

5.2.6.2.5 Each outlet shall be sized to deliver foam at approximately the same minimum application rate or higher.

5.3.1 Tanks equipped with the following floating roof types shall not be covered in Section 5.3:

- (1) Roofs made from floating diaphragms
- (2) Roofs made from plastic blankets
- (3) Roofs made from plastic or other flotation material, even if encapsulated in metal or fiberglass
- (4) Roofs that rely on flotation device closures that can-be are easily submerged if damaged
- (5) Pan roofs

5.3.5.2.2 ~~There shall be two acceptable arrangements where fixed foam discharge outlets are utilized. The following shall be permitted to be two methods of application of fixed foam discharge outlets:~~

- (1) Fixed foam discharge outlets (normally Type II) mounted above the top of the tank shell
- (2) Fixed foam discharge outlets mounted on the periphery of the floating roof

Move to annex of A.5.3.5.4.5:

A.5.3.5.4.6 Excessive dam openings for drainage shall be avoided prohibited to prevent loss of foam through the drainage slots.

5.4.1 Requirements for tanks equipped with the following floating roof types shall not be covered in Section 5.4:

- (1) Roofs made from floating diaphragms
- (2) Roofs made from plastic blankets
- (3) Roofs made with plastic or other flotation material, even if encapsulated in metal or fiberglass
- (4) Roofs that rely on flotation device closures that can be are easily submerged if damaged
- (5) Pan roofs

5.4.2 Seal area protection systems shall be permitted for the following types of roof construction shall be considered suitable for seal area protection systems:

- (1) Steel double deck
- (2) Steel pontoon
- (3) Full liquid surface contact, metallic sandwich panel, conforming to Appendix H, "Internal Floating Roofs" requirements of API 650

5.4.2.2.1 Where the basis for design is a full surface fire, the covered (internal) floating roof tank shall be considered treated as equivalent to a fixed-roof (cone) tank of the same diameter for the purpose of foam system design.

5.4.2.3.1 Where the basis for design is a seal fire, the covered (internal) floating roof tank shall be considered treated as equivalent to an open-top floating roof tank of the same diameter for the purpose of foam system design.

5.6.2 Total rack size, flammable or combustible products involved, proximity of other hazards and exposures, drainage facilities, wind conditions, ambient temperatures, and available staff all shall be considered factored into the design of a loading rack foam system.

5.6.3 Methods of Protection. The following shall be permitted to be two acceptable methods of protecting loading racks:

- (1) Foam-water sprinkler application utilizing air-aspirating foam-water sprinklers or nozzles or non-air-aspirating standard sprinklers
- (2) Foam monitors

5.7.3.4.2* Where foam-water sprinklers or nozzles are used as the primary protection, consideration the design shall be given to include the possibility that some of the foam discharge can will be carried by the wind beyond the area of the fuel spill.

5.7.3.5.4.1 Where foam monitors are used as the primary protection, consideration the design shall be given to include the possibility that some of the foam discharge can will be carried by the wind beyond the area of the fuel spill.

5.9.2.1 Description of Areas. For the purpose of this standard, nondiked spill areas shall be are areas where a flammable or combustible liquid spill might can occur, uncontained by curbing, dike walls, or walls of a room or building.

5.9.2.2 The minimum number of fixed or portable hose streams required shall be as specified in Table 5.9.2.2 and shall be available to provide protection of the area.

Committee Meeting Action: Accept

Number Eligible to Vote: 27

Ballot Results: Affirmative: 24

Ballot Not Returned: 3 LaVergne, E., Santerre, G., Williams, M.

11-25 Log #16
(Table 5.2.5.2.2)

Final Action: Accept in Principle

Submitter: Eldon D. Jackson, The Viking Corporation

Recommendation: Delete text as follows:

~~Type I Foam Discharge Outlet (Minimum discharge time)~~

Substantiation: Delete allowance for reduced time when using a Type I discharge device as all have been obsolete and actually turn into Type II discharge devices when mechanical failure occurs. Clean up section due to non use.

Committee Meeting Action: Accept in Principle

Revise the following sections as indicated below.

Revise Table 5.2.5.2.2 and Table 5.2.5.3.4 and Section A.5.2.5.2.2 to remove references to Type I Discharge Outlets and relocate information to new Annex A Section A.5.2.5.2.2.

Add note 4 in Table 5.2.5.2.2 and note 2 in Table 5.2.5.3.4 as follows: Type I discharge outlets are considered obsolete and those outlets currently installed become Type II outlets if damaged. Refer to Section A 3.3.5.2 for additional information and application for existing Type I outlets.

| Hydrocarbon Type | Minimum Application Rate | | Minimum Discharge Time (min) | |
|---|--------------------------|---------------------|------------------------------|-------------------------------|
| | L/min /m ² | gpm/ft ² | Type I Foam Discharge Outlet | Type II Foam Discharge Outlet |
| Flash point between 37.8°C and 60°C (100°F and 140°F) | 4.1 | 0.10 | 20 | 30 |
| Flash point below 37.8°C (100°F) or liquids heated above their flash points | 4.1 | 0.10 | 30 | 55 |
| Crude petroleum | 4.1 | 0.10 | 30 | 55 |

Notes:

- (1) Included in this table are gasohols and unleaded gasolines containing no more than 10 percent oxygenated additives by volume. Where oxygenated additives content exceeds 10 percent by volume, protection is normally in accordance with 5.2.5.3. Certain nonalcohol-resistant foams might be suitable for use with fuels containing oxygenated additives of more than 10 percent by volume. The manufacturer shall be consulted for specific listings or approvals.
- (2) Flammable liquids having a boiling point of less than 37.8°C (100°F) might require higher rates of application. Suitable rates of application should be determined by test.
- (3) For high-viscosity liquids heated above 93.3°C (200°F), lower initial rates of application might be desirable to minimize frothing and expulsion of the stored liquid. Good judgment should be used in applying foams to tanks containing hot oils, burning asphalts, or burning liquids that have boiling points above the boiling point of water. Although the comparatively low water content of foams can beneficially cool such liquids at a slow rate, it can also cause violent frothing and "slop-over" of the tank's contents.
- (4) Type I discharge outlets are considered obsolete and those currently installed become Type II outlets if damaged. Refer to Section A 5.2.5.2.2 for additional information and minimum discharge times for existing Type I outlets.

| Application Rate for Specific Product Stored | Minimum Discharge Time (min) | |
|--|------------------------------|-------------------------------|
| | Type I Foam Discharge Outlet | Type II Foam Discharge Outlet |
| Consult manufacturer for listings on specific products | 30 | 55 |

Note: Most currently manufactured alcohol

Notes:

(1) Most currently manufactured alcohol-resistant foams are suitable for use with Type II fixed foam discharge outlets. However, some older alcohol-resistant foams require gentle surface application by Type I fixed foam discharge outlets. Consult manufacturers for listings on specific products.

(2) Type I discharge outlets are considered obsolete and those currently installed become Type II outlets if damaged. Refer to Section A 5.2.5.3.4 for additional information and minimum discharge times for existing Type I outlets.

Submitter: Technical Committee of Foam,

Recommendation: Revise the following sections as indicated below.

Revise Table 5.2.5.2.2 and Table 5.2.5.3.4 and Section A.5.2.5.2.2 to remove references to Type I Discharge Outlets and relocate information to new Annex A Section A.5.2.5.2.2.

Add note 4 in Table 5.2.5.2.2 and note 2 in Table 5.2.5.3.4 as follows: Type I discharge outlets are considered obsolete and those outlets currently installed become Type II outlets if damaged. Refer to Section A 3.3.5.2 for additional information and application for existing Type I outlets.

Substantiation: Type I outlets are obsolete and should be removed from the main body of the standard.

New Section

A.5.2.5.2.2 Minimum Discharge Times and Application Rate for existing Type I Fixed Foam Discharge Outlets. Type I discharge outlets are considered obsolete and Type I outlets that are damaged effectively become Type II outlets. Minimum discharge times and application rates for Type I outlets currently installed are provided in Table A.5.2.5.2.2 for fixed roof tanks storing hydrocarbons and in Table A.5.2.5.3.4 for flammable and combustible liquids requiring alcohol-resistant foams.

6.7.4.2 All operating devices shall be suitable approved for the service they will encounter and shall not be readily rendered inoperative or susceptible to accidental operation.

6.7.4.4 Manual controls for actuation and shutdown shall be conveniently located and easily accessible at all times, including the time of fire and system operation.

6.7.4.4.1 Remote control stations for manual actuation ~~should~~ shall be considered where the area is large, egress difficult, or where required by the AHJ.

6.7.4.5.2 The emergency means, preferably mechanical, shall be easily accessible and located close to the equipment controlled.

6.7.4.5.3 If possible, the system shall be designed so that complete emergency actuation can shall be permitted to be accomplished from one location.

Table A 5.2.5.2.2 Minimum Discharge Times and Application Rate for existing Type I and Type II Fixed Foam Discharge Outlets on Fixed-Roof (Cone) Storage Tanks Containing Hydrocarbons

| Hydrocarbon Type | Minimum Application Rate | | Minimum Discharge Time (min) |
|---|--------------------------|---------------------|------------------------------|
| | L/min ■m ² | gpm/ft ² | Type I Foam Discharge Outlet |
| Flash point between 37.8°C and 60°C (100°F and 140°F) | 4.1 | 0.10 | 20 |
| Flash point below 37.8°C (100°F) or liquids heated above their flash points | 4.1 | 0.10 | 30 |
| Crude petroleum | 4.1 | 0.10 | 30 |

Committee Statement: Type I outlets are obsolete and should be removed from the main body of the standard.

Number Eligible to Vote: 27

Ballot Results: Affirmative: 24

Ballot Not Returned: 3 LaVergne, E., Santerre, G., Williams, M.

11-26 Log #25
(5.6)

Final Action: Reject

Submitter: Gaston J. Santerre, Integrated Protection Services Inc.

Recommendation: Add new text as follows:

Require that loading racks with foam deluge systems should be able to apply foam solution in a maximum of 60 seconds from when the deluge valve trips.

Substantiation: Many racks that are being tested can take as long as (2) two minutes before foam solution is introduced at the rack. Two minutes for a flammable liquid fire can be devastating.

Committee Meeting Action: Reject

Committee Statement: The committee cannot substantiate a response time to deliver foam to the hazard that would meet all applications.

Number Eligible to Vote: 27

Ballot Results: Affirmative: 24

Ballot Not Returned: 3 LaVergne, E., Santerre, G., Williams, M.

11-27 Log #CP3

Final Action: Accept

(6.2.1, 6.3.2, 6.7.1.3, 6.7.3.4, 6.7.4.2, 6.7.4.4.1, 6.7.4.5.2, 6.7.4.5.3, 6.8.1.2, 6.9.3, 6.11.2.1, 6.11.3.2.1, 6.12.2, 6.12.10.3.2, A.6.12.10.3.2, 6.12.4.1.1.2, 6.12.4.1.2.3, 6.12.5.1, 6.12.8.)

Submitter: Technical Committee on Foam,

Recommendation: Revise the following Sections to read as follows:

6.2.1 Medium- and high-expansion foams shall be specifically evaluated to verify the applicability of medium- or high-expansion foam as a fire control agent for the type of hazard being considered for application of foam.

6.3.2* Medium- and high-expansion foam systems shall not be used on fires in the following hazards:

(1) Chemicals, such as cellulose nitrate, that release sufficient oxygen or other oxidizing agents to sustain combustion

6.7.1.3 Detection by the use of combustible vapor detectors or an abnormal condition in the hazard such as process trouble, ~~likely to produce fire~~, shall be arranged using acceptable approved industrial practices as specified by an engineering study.

6.7.3.4 Alarms shall be provided to give ample warning of discharge where hazards(s) to personnel might exist.

6.8.1.2 The quality of the concentrate for ~~proper~~ performance under the installation requirements of this standard shall be determined by suitable tests.

6.9.3 Vents from the fire area shall be located to avoid prevent recirculation of combustion products or other materials deleterious to the formation of foam into foam generator air inlets.

6.11.2.1 A listed strainer suitable for use with the proportioner and foam generator shall be provided in the water line upstream of the water valve.

6.11.3.2.1 When duct closures are located where they ~~might be~~ are subjected to fire or heat exposure, either inside or outside the area to be protected, special care shall be taken to ensure positive operation.

6.12.2* Applications. Total flooding systems are permitted to be used where an adequate permanent enclosure is provided around the hazard to enable the required amount of fire-extinguishing medium to accumulate at the proper depth and to be maintained for a period of time required to ensure fire control or extinguishment in a specific combustible material.

6.12.10.3.2 Arrangements and procedures shall be provided to maintain the submergence volume without waste of foam concentrate. ~~that might be needed should reignition occur.~~

A.6.12.10.3.2 Additional foam concentrate could be needed should reignition occur.

6.12.4.1.1.2 Where openings cannot be protected by automatic closing devices, the total flooding system shall be designed to compensate for the probable loss of foam.

(A) ~~The suitability of the system design~~ shall be tested to ensure proper performance.

(B) If the foam system ~~can be~~ is permitted to started prior to complete closure of the space to be filled, additional foam output shall be allowed to compensate for the losses.

(C) This shall be verified by test based on the individual site conditions.

6.12.4.1.2.3 The required venting shall consist of suitable openings, either normally open or normally closed and arranged to open automatically when the system operates.

6.12.5.1 General. For adequate protection, ~~Total flooding~~ medium- or high-expansion foam shall be discharged at a rate sufficient required to fill the enclosure to an effective depth above the hazard before an unacceptable degree of damage occurs.

6.12.8.2.1* The rate of foam discharge necessary for extinguishment or sufficient control to permit overhaul shall be dependent on the strength of sprinkler protection, the nature and configuration of the hazard, the vulnerability of the structure and contents to fire, and the loss potential to life, property, and production.

6.12.8.2.2 The foam discharge rate shall meet be sufficient to satisfy the foam depth requirements and submergence times of Table 6.12.7.1, with compensation for normal foam shrinkage, foam leakage, and breakdown effects of sprinkler discharge.

(4)* The factor (CL) for compensation for loss of foam due to leakage around doors and windows and through uncloseable openings shall be determined by the design engineer after proper evaluation of the structure. This factor ~~cannot shall not be permitted~~ to be less than 1.0 even for a structure completely tight below the design filling depth. This factor ~~could shall be permitted~~ to be as high as 1.2 for a building with all openings normally closed, depending on foam expansion ratio, sprinkler operation, and foam depth.

6.12.9.1 Sufficient High-expansion foam concentrate and water shall be provided to permit continuous operation of the entire system for 25 minutes or to generate four times the submergence volume, whichever is less, but in no case less than enough for 15 minutes of full operation.

6.12.9.2 The quantity for medium-expansion foam shall be determined by suitable tests developed by an independent testing laboratory.

6.12.10.1 To ensure adequate control or extinguishment, the submergence volume shall be maintained for at least 60 minutes for unsprinklered locations and 30 minutes for sprinklered locations.

6.12.10.4* Overhaul. Overhaul procedures shall be preplanned carefully to prevent loss of control by submergence of the hazard.

6.13.1.2.2 For multiple-level or three-dimensional fire hazards where total building flooding is impractical, the individual hazard shall be provided with suitable containment facilities.

6.13.3.1 Extent of Hazard. The hazard shall include all areas to or from which fire can spread.

6.13.3.3.1 General. Sufficient Foam shall be discharged at a rate to cover the hazard to a depth of at least 0.6 m (2 ft) within 2 minutes.

6.13.3.3.2.1 Sufficient Foam concentrate and water shall be provided to permit continuous operation of the entire system for at least 12 minutes.

6.13.3.3.3.2 Where parts of the hazard are elevated or raised up from the ground or floor line, the arrangement of the system shall be such that foam will be delivered to, and retained on, such parts in sufficient the required depth to ensure prompt and final extinguishment.

6.14.1.2 The analysis shall consider include effects of heat exposure on adjacent plant equipment.

6.14.3.1 The initial quantity of foam concentrate shall permit a continuous application at the initial design rate sufficient for fire control to reach steady-state conditions.

6.15.1.1.2 The proportioning equipment can shall be integral to or separate from the foam generator.

6.15.3.1 Portable foam-generating devices that are preconnected to a water or solution supply shall be placed where they are easily accessible and shall have enough hose to reach the most distant hazard they are expected to protect.

6.15.3.2 Foam concentrate shall be available accessible for immediate use.

6.15.4.1.2 To the extent that the specific hazards can be are identified, the applicable requirements of this chapter shall apply.

6.15.4.1.3 Simultaneous Use of Portable Foam-Generating Devices. Where simultaneous use of two or more devices is possible, sufficient supplies of foam concentrate and water shall be available accessible to supply the maximum number of devices that are likely physically possible to be used at any one time.

6.15.5.2.1 Power supply and connections needed for operation of the generator shall be adequate to capable of transmitting the required power and shall be selected with consideration given to for the intended use.

6.15.6* Training. All personnel likely to use portable generating equipment shall be properly trained to use in the operation of portable generating equipment in its operation and in the necessary fire-fighting techniques.

Substantiation: Removes unenforceable language as per the NFPA Manual of Style.

Committee Meeting Action: Accept

Number Eligible to Vote: 27

Ballot Results: Affirmative: 24

Ballot Not Returned: 3 LaVergne, E., Santerre, G., Williams, M.

11-28 Log #CP20
(6.3.2)

Final Action: Accept

Submitter: Technical Committee on Foam,

Recommendation: Revise Section 6.3.2 to read as follows:

6.3.2* Medium- and high-expansion foam systems shall not be used on fires in the following hazards except where competent evaluation, including tests, indicates acceptability:

(1) Chemicals, such as cellulose nitrate, that release sufficient oxygen or other oxidizing agents to sustain combustion

(2) Energized unenclosed electrical equipment

(3) Water-reactive metals such as sodium, potassium, and NaK (sodium-potassium alloys)

(4) Hazardous water-reactive materials, such as triethyl-aluminum and phosphorus pentoxide

(5) Liquefied flammable gas

(6) Hazards listed in (1)-(5) where competent evaluation, including tests, indicates acceptability

Substantiation: Better clarifies the intent.

Committee Meeting Action: Accept

Number Eligible to Vote: 27

Ballot Results: Affirmative: 24

Ballot Not Returned: 3 LaVergne, E., Santerre, G., Williams, M.

Comment on Affirmative:

BATEMAN, V.: Add water miscible or polar solvents to hazards, or define use as below:

High expansion foam is intended for use on fires involving ordinary hydrocarbon petroleum products and in controlling fires in ordinary Class A combustibles.

11-29 Log #CP4
(7.2.3, 7.3.6)

Final Action: Accept

Submitter: Technical Committee on Foam,

Recommendation: Revise the following Sections to read as follows:

7.2.3 The specifications shall include the specific tests that might be required to meet the approval of the AHJ and shall indicate how testing costs are to be met.

7.3.6 Where field conditions necessitate any significant change affecting system performance from the approved plan, revised "as installed" plans shall be supplied for approval to the AHJ.

Substantiation: Removes unenforceable language as per the NFPA Manual of Style.

Committee Meeting Action: Accept

Number Eligible to Vote: 27

Ballot Results: Affirmative: 24

Ballot Not Returned: 3 LaVergne, E., Santerre, G., Williams, M.

11-30 Log #6
(7.15)

Final Action: Accept

Submitter: Raymond Quenneville, FireFlex Systems, Inc.

Recommendation: Revise text to read as follows:

"...but in no case less than 1.63 l/min/square meter (0.04 gpm/square ft) for hydrocarbon fuel applications and 2.3 l/min/square meter (0.06 gpm/square ft) for alcohol and ketone applications.

Substantiation: Additional testing has been conducted to extend the listing of the technology for Polar Solvent applications. The enclosed FM Approval report 3026593 is provided as supporting document for the above proposal.

Note: Supporting material is available for review at NFPA Headquarters.

Committee Meeting Action: Accept

Number Eligible to Vote: 27

Ballot Results: Affirmative: 21 Negative: 2 Abstain: 1

Ballot Not Returned: 3 LaVergne, E., Santerre, G., Williams, M.

Explanation of Negative:

BATEMAN, V.: This section recommends minimum application rates at the test rates detailed in the supporting material. There is no design guideline to account for possibility of the foam being carried by wind, etc. Is the assumption that these devices would always be in a protected area and would not need to accommodate corrective design calculations? Test details in the supporting material also deviate from standard UL/FM tests by using a shortened preburn time. Foam discharge times as recommended in Section 7.16 also do not anticipate foam loss due to wind.

PURVIS, F.: As stated above, design application density based on test rate with no safety factor is not appropriate. Laboratory scale testing can not account for conditions that will be encountered in full scale installations. Some of these include damage or plugging of foam discharge devices, affect of wind and updraft that will easily carry expanded foam away from the intended hazard area, and obstructions in the hazard area that will hinder foam application to "shadow" areas.

Explanation of Abstention:

BENZENBERG, G.: My reasons for Abstaining was that I was not in attendance at the last meeting and did not hear the discussion.

11-31 Log #CP5
(8.1.2, 8.2.1, 8.5.6, 8.6.5)

Final Action: Accept

Submitter: Technical Committee on Foam,

Recommendation: Revise the following Sections to read as follows:

8.1.2 Positive displacement pumps and centrifugal pumps are capable of overpressuring the system and shall be provided with adequate means of pressure relief from the discharge to the supply side of the circuit to prevent excessive pressure and temperature.

8.2.1 Pumps shall be provided with an adequate means for flushing with water.

8.5.6 Drain valves that are readily accessible shall be provided for low points in underground and aboveground piping.

8.6.5 Attachments can shall be made to existing steel or concrete structures and equipment supports.

Substantiation: Removes unenforceable language as per the NFPA Manual of Style.

Committee Meeting Action: Accept

Number Eligible to Vote: 27

Ballot Results: Affirmative: 24

Ballot Not Returned: 3 LaVergne, E., Santerre, G., Williams, M.

11-32 Log #CP19 **Final Action: Accept**
(8.5.6)

Submitter: Technical Committee on Foam,

Recommendation: Add a new Section 8.5.6 to read as follows:

8.5.6* Bladder Tank Valves

8.5.6.1 For bladder tank systems with multiple risers, the water supply feed to the bladder tank shall be arranged to prevent the discharge of foam concentrate into risers that have been isolated to prevent further discharge into the hazard.

8.5.6.2 For single riser systems, the water feed to the bladder tank shall be located above the system control valve.

A.8.5.6 Failure to isolate the water supply feed to the bladder tank can cause a continuation of foam concentrate discharge into the system riser. This continued discharge can cause damage to the bladder, siphon tube inside the tank and can waste foam concentrate. Risers that have filled with foam concentrate due to this issue can be inadvertently drained thus contaminating the environment with foam concentrate.

Substantiation: Failure to isolate the water supply feed to the bladder tank can cause a continuation of foam concentrate discharge into the system riser. This continued discharge can cause damage to the bladder, siphon tube inside the tank and can waste foam concentrate. Risers that have filled with foam concentrate due to this issue can be inadvertently drained thus contaminating the environment with foam concentrate.

Committee Meeting Action: Accept

Number Eligible to Vote: 27

Ballot Results: Affirmative: 24

Ballot Not Returned: 3 LaVergne, E., Santerre, G., Williams, M.

11-33 Log #CP6 **Final Action: Accept**
(9.1.3.1, 9.1.3.2, 9.1.4.3, 9.2.1, 9.2.3, 9.2.4, 9.3.2.2, 9.3.4.2, 9.5.6.3, 9.6.3, 9.8.2, 9.10.3, 9.11.2.4, 9.11.3)

Submitter: Technical Committee on Foam,

Recommendation: Revise the following Sections to read as follows:

9.1.3.1 All components shall be suitable listed or approved for their intended application and shall be approved for use in a marine environment.

9.1.3.2 Each manufacturer shall maintain a system design manual describing basic acceptable system design arrangements and denoting each of the manufacturers' products within the system.

9.1.4.3* Concentrates intended for use on polar solvent systems shall be approved for hydrocarbons in accordance with 9.1.4.1 and approved for use on polar solvents in accordance with a method equivalent comparable to UL 162.

9.2.1* Where installed, systems protecting machinery spaces shall be capable of discharging a sufficient the required quantity of expanded foam to provide a foam depth of at least 150 mm (6 in.) over the largest area over which oil is likely expected to spread.

9.2.3 The system shall be capable of generating foam suitable for extinguishing hydrocarbon fires.

9.2.4 Means shall be provided for effective distribution of the foam through a permanent system of piping and control valves to suitable discharge outlets and for foam to be effectively directed by fixed foam outlets.

9.3.2.2* Operating instructions and diagrams of piping systems and valves shall be provided in clear and permanent lettering and shall be affixed to the equipment or in a position near visible thereto.

9.3.4.2 Rate of application for polar solvents shall be as follows:

(1) Since required foam application rates can be permitted to vary, polar solvents are placed in representative groups based upon fire performance tests.

(2) Fire tests are used to determine the minimum foam design application rate for the group and are conducted using one or more solvents representing the most difficult extinguishment case or the actual polar solvent.

(3) The following minimum foam design application rates and polar solvent groupings shall be specified in the foam manufacturer's system design manual and shall be approved:

(a) Deck spill calculation: the highest required foam application rate for any polar solvent that can be permitted to be transported by the ship, applied over 10 percent of the cargo block deck area, where the cargo block deck area is the maximum breadth of the ship multiplied by the total longitudinal extent of the cargo tank spaces

(b) Most demanding tank calculation: 150 percent of the highest required foam application rate, for any polar solvent that can be permitted to be transported by the ship, applied over the horizontal sectional area of the single largest tank

(c) Where dedicated cargo tanks are specifically designed for a particular polar solvent and such solvent cannot be carried in other tanks, the foam system design can be permitted to take into consideration this limitation.

(d) Largest monitor calculation: 45 percent of the highest required foam application rate for any polar solvent that can be permitted to be transported by the ship, applied over the area protected by the foam monitor, such area being entirely orward of the monitor, but not less than 1250 L/min (330 gpm)

9.5.6.3 Foam monitors shall be mounted on substantial platforms.

9.6.3 The number and location of foam solution outlets shall be such that foam from at least two hand hoses can be permitted to be simultaneously directed onto any part of the cargo block deck area.

9.8.2 Isolation valves shall be operable from readily accessible locations.

9.10.3 The system supplier or owner shall make available provide to the ship's crew a system use, inspection, and testing videotape.

9.11.2.4 Each tank shall have a substantial support structure suitable for mounting the tank to the ship's structure.

9.11.3 Tanks shall be of a design and materials proven to be suitable designed for use with constant sloshing of the liquid against the tank structure.

Substantiation: Removes unenforceable language as per the NFPA Manual of Style.

Committee Meeting Action: Accept

Number Eligible to Vote: 27

Ballot Results: Affirmative: 24

Ballot Not Returned: 3 LaVergne, E., Santerre, G., Williams, M.

11-34 Log #CP1 **Final Action: Accept**
(10.1, 10.2, 10.3*, A.10.3, 10.4, 10.5, 10.6*, A.10.6, 10.7, 10.8)

Submitter: Technical Committee on Foam,

Recommendation: Revise Chapter 10 to read as follows:

10.1 Inspection and Visual Examination.

10.1.1 Foam systems shall be examined visually to determine that they have been properly installed in accordance with approved plans and specifications.

10.1.2 Foam systems shall be inspected for such items as conformity with installation plans; continuity of piping; removal of temporary blinds; accessibility of valves, controls, and gauges; and proper installation of vapor seals, where applicable.

10.1.3 Devices shall be checked for proper identification and operating instructions.

10.2 Flushing after Installation.

10.2.1 In order to remove foreign materials that have entered both underground and aboveground water supply mains during installation, the water supply mains shall be flushed thoroughly at the maximum practicable rate of flow before connection is made to system piping.

10.2.2 The minimum rate of flow for flushing shall not be less than the water demand rate of the system, as determined by the system design.

10.2.3 The flow shall be continued for a time to ensure thorough cleaning.

~~**10.2.3.1** Tests shall include a complete check of electrical control circuits and supervisory systems to ensure proper operation and supervision in the event of failure.~~

~~**10.2.4** Disposal of flushing water shall be arranged:~~

~~**10.2.5** All foam system piping shall be flushed after installation, using the system's normal water supply with foam-forming materials shut off, unless the hazard cannot be subjected to water flow.~~

~~**10.2.6** Where flushing cannot be accomplished, pipe interiors shall be carefully visually examined for cleanliness during installation.~~

~~**A.10.3* Acceptance Tests.**~~

~~**A.10.3** Acceptance tests should encompass the following:~~

~~(1) A foam system will extinguish a flammable liquid fire if operated within the proper ranges of solution pressure and concentration and at sufficient discharge density per square foot (square meter) of protected surface. The acceptance test of a foam system should ascertain the following:~~

~~(a) All foam-producing devices are operating at system design pressure and at system design foam solution concentration.~~

~~(b) Laboratory-type tests have been conducted, where necessary, to determine that water quality and foam liquid are compatible.~~

~~(2) The following data are considered essential to the evaluation of foam system performance:~~

~~(a) Static water pressure~~

~~(b) Stabilized flowing water pressure at both the control valve and a remote reference point in the system~~

~~(c) Rate of consumption of foam concentrate~~

~~The concentration of foam solution should be determined. The rate of solution discharge can be computed from hydraulic calculations utilizing recorded inlet or end-of-system operating pressure or both. The foam liquid concentrate consumption rate can be calculated by timing a given displacement from the storage tank or by refractometric or conductivity means. The calculated concentration and the foam solution pressure should be within the operating limit recommended by the manufacturer.~~

~~**10.3.1** The completed system shall be tested by qualified personnel to meet the approval of the AHJ.~~

~~**10.3.2** These tests shall be used to determine that the system has been properly installed in accordance with approved plans and specifications, and that it functions as intended.~~

~~**10.4 Pressure Tests.**~~

~~**10.4.1** All piping, except piping handling expanded foam for other than subsurface application, shall be subjected to a 2-hour hydrostatic pressure gauge test at 1379 kPa (200 psi) or 345 kPa (50 psi) in excess of the maximum pressure anticipated, whichever is greater, in accordance with NFPA 13.~~

~~**10.4.2** Drainage pitch for A all normally dry horizontal piping shall be verified. inspected for drainage pitch.~~

10.5 Operating Tests.

10.5.1 Before approval, all operating devices and equipment shall be tested for proper function.

10.5.2 Tests for total flooding systems shall establish that all automatic closing devices for doors, windows, and conveyor openings, and automatic equipment interlocks, as well as automatic opening of heat and smoke vents or ventilators, will function upon system operation.

10.5.3 ~~10.2.3.1~~ Tests shall include a complete check of electrical control circuits and supervisory systems to ensure proper operation and supervision in the event of failure.

10.5.34 Operating instructions provided by the supplier and proper device identification shall be checked ~~verified~~.

10.6* Discharge Tests.

A.10.6 The rate of concentrate consumption can be measured by timing a given displacement from the foam concentrate storage tank, but only in systems where the storage tank is small enough and the test run time is long enough so that this can be accomplished with reasonable accuracy.

10.6.1 Where conditions permit, flow tests shall be conducted to ensure that the hazard is fully protected in conformance with the design specification.

10.6.2 The following data shall be required:

- (1) Static water pressure
- (2) Residual water pressure at the control valve and at a remote reference point in the system
- (3) Actual discharge rate
- (4) Consumption rate of foam-producing material
- (5) Concentration of the foam solution
- (6) Foam quality (expansion and one-quarter drain time) or foam discharge shall be conducted, or the foam discharge shall be visually inspected to ensure that it is satisfactory for ~~meets~~ the purpose intended.

10.6.3 Foam concentration shall have one of the following proportions:

- (1) Not less than the rated concentration
- (2)* No more than 30 percent above the rated concentrate, or 1 percentage point above the rated concentration (whichever is less) (For information on tests for physical properties of foam, see Annex D.)

A.10.6.3(2) The rate of concentrate flow can be measured by timing a given displacement from the storage tank. Solution concentration can be measured by either refractometric or conductivity means (see Section D.2), or it can be calculated from solution and concentrate flow rates. Solution flow rates can be calculated by utilizing recorded inlet or end-of-system operating pressures or both.

10.7 Approval of Low, Medium and High Expansion Foam Systems.

The installing contractor shall perform the following tasks:

(1) Notify the authority having jurisdiction and the property owner or the property owner's authorized representative of the time and date testing will be performed

(2) Perform all acceptance tests required by this chapter.

(3) Complete and sign the contractor's material and test certificate for low, medium and high expansion foam systems

10.78 System Restoration. After acceptance tests are completed, the system shall be flushed and restored to operational condition.

Substantiation: 10.1.1 Removes unenforceable text.

10.1.3 Removes unenforceable text

10.2.3 Removes unenforceable text

10.2.3.1 Moved to section 10.5.3. This text properly belongs under 10.5 Operating Tests, not 10.2 Flushing After Installation.

10.3.2 Removes unenforceable text

10.4.2 New wording clarifies intent.

10.5.1 Removes unenforceable text

10.5.3 See 10.2.3.1.

10.5.4 Removes unenforceable text

10.6.2(6) Removes unenforceable text

10.7 New language provides requirements for the conduct and documentation of acceptance testing.

Committee Meeting Action: Accept

Number Eligible to Vote: 27

Ballot Results: Affirmative: 23 Negative: 1

Ballot Not Returned: 3 LaVergne, E., Santerre, G., Williams, M.

Explanation of Negative:

BENZENBERG, G.: My reason for a negative vote was do to the deletion of 10.2.3.1 Testing of Electrical control equipment. This may have been in the wrong paragraph but still needs to be in the standard.

11-35 Log #CP2

Final Action: Accept in Principle

(10.3.3 (New))

Submitter: Technical Committee on Foam,

Recommendation: Add new Section 10.3.3 to read as follows:

10.3.3 The installing contractor shall complete and sign the Contractor's Material and Test Certificate for Low Expansion Foam Systems in Figure 10.3.3.

(See Figure 10.3.3 Contractor's Material and Test Certificate for Low Expansion Foam Systems on pages 15, 16, and 17.)

Substantiation: Guidance for the documentation of acceptance test results is needed.

Committee Meeting Action: Accept in Principle

Committee Statement: A task group has been formed to finalize a version of the proposed test certificate.

Number Eligible to Vote: 27

Ballot Results: Affirmative: 24

Ballot Not Returned: 3 LaVergne, E., Santerre, G., Williams, M.

11-36 Log #24

Final Action: Accept in Principle

(10.6.2)

Submitter: Gaston J. Santerre, Integrated Protection Services Inc.

Recommendation: Add new text as follows:

Acceptance testing utilizing alternative liquids that exhibit the same shear and viscosity characteristics as the existing foam concentrate but is environmentally benign shall be acceptable.

Substantiation: Many cities/municipalities will not allow testing of actual foam concentrates due to the chemical composition of these foams.

Committee Meeting Action: Accept in Principle

Revise the proposed language to read as follows:

10.6.2 A listed alternative liquid that mimics the foam concentrate flow properties shall be permitted to be used to test the proportioning system if the local AHJ permits the substitution.

Committee Statement: Meets the intent of the submitter.

Number Eligible to Vote: 27

Ballot Results: Affirmative: 24

Ballot Not Returned: 3 LaVergne, E., Santerre, G., Williams, M.

11-37 Log #CP21

Final Action: Accept

(10.6.2(6))

Submitter: Technical Committee on Foam,

Recommendation: Delete Section 10.6.2(6) as shown:

10.6.2 The following data shall be required:

- (1) Static water pressure
- (2) Residual water pressure at the control valve and at a remote reference point in the system
- (3) Actual discharge rate
- (4) Consumption rate of foam-producing material
- (5) Concentration of the foam solution
- (6) ~~Foam quality (expansion and one-quarter drain time) or foam discharge shall be conducted, or the foam discharge shall be visually inspected to ensure that it is satisfactory for the purpose intended.~~

Substantiation: It is not the intent to require foam quality testing. There is also no acceptance criteria for this test.

Committee Meeting Action: Accept

Number Eligible to Vote: 27

Ballot Results: Affirmative: 23 Negative: 1

Ballot Not Returned: 3 LaVergne, E., Santerre, G., Williams, M.

Explanation of Negative:

RAMSDEN, N.: I believe it is a retrograde step to remove the requirement to carry out regular foam quality checks. I accept that there are sometimes difficulties in carrying out the discharge test due to environmental or operational reasons, but this is no excuse not to do the test.

Doing discharge tests and measuring foam quality is, ultimately, the only way to check the whole system.

Comment on Affirmative:

KASISKI, R.: I agree with the Technical Committee a Foam Quality test is not necessary for those discharge devices which are listed with their respective foam concentrate and proportioning device. But not all discharge devices are listed and therefore whether a fire test or comparative foam quality evaluation was conducted on the fire performance of the device is not known. I believe clarification (separate requirement) on the application of the foam quality testing requirement to those discharge devices not listed or evaluated for fire test performance would be more appropriate than the deletion of the data point from paragraph 10.6.2 of Section 10.6 - Discharge Tests.

11-38 Log #CP10

Final Action: Accept

(11.1, 11.4, 11.2.2)

Submitter: Technical Committee on Foam,

Recommendation: Revise the following Sections to read as follows:

11.1* Periodic Inspection, Testing and Maintenance.

11.4 Strainers. Strainers shall be inspected periodically in accordance with manufacturer's instructions and shall be cleaned after each use and flow test.

11.2.2 Fixed discharge outlets equipped with frangible seals shall be provided with suitable inspection means to permit proper maintenance and for inspection and replacement of vapor seals.

Substantiation: Removes unenforceable language as per the NFPA Manual of Style.

Committee Meeting Action: Accept

Number Eligible to Vote: 27

Ballot Results: Affirmative: 24

Ballot Not Returned: 3 LaVergne, E., Santerre, G., Williams, M.

Contractor's Material and Test Certificate for Low Expansion Foam Systems

Property Name: _____ Date: _____

Address: _____

Contract #: _____

Procedure

Upon completion of work, inspection and tests shall be made by the contractor's representative and witnessed by an owner's representative. All defects shall be corrected and the system left in service before contractor's personnel finally leave the job.

A certificate shall be filled out and signed by both representatives. Copies shall be prepared for approving authorities, owners, and contractors. It is understood that the owner's representative's signature in no way prejudices any claim against contractor for faulty material, poor workmanship, or failure to comply with approving authority's requirements or local ordinances.

Plans

Accepted by [approving authority's name(s)] _____

Address _____

Installation conforms to accepted plans? Yes No

Equipment used is approved? Yes No

If no, explain deviations. _____

Instructions

Has person in charge of fire equipment been instructed as to location of control valves and care and maintenance of this new equipment? Yes No

If no, explain. _____

Have copies of appropriate instructions and care and maintenance charts and NFPA 11 been left on premises? Yes No

If no, explain. _____

Location of System

Supplies building/Area _____

Discharge Devices

| Make | Model | Year of Manufacture | Orifice Size | Quantity | Other |
|------|-------|---------------------|--------------|----------|-------|
| | | | | | |
| | | | | | |
| | | | | | |
| | | | | | |

Pipe and Fittings

Pipe conforms to _____ standard. Yes No

Fittings conform to _____ standard. Yes No

If no, explain. _____

Contractor's Material and Test Certificate for Low Expansion Foam Systems

Alarm Valve or Flow Indicator

| Type | Alarm Device | | Maximum Time to Operate Through Test Pipe | |
|------|--------------|-------|---|---------|
| | Make | Model | Minutes | Seconds |
| | | | | |
| | | | | |

Deluge and Preaction Valves

Operation Pneumatic Electric Hydraulic
 Piping supervised? Yes No Detecting media supervised? Yes No
 Is there an accessible facility in each circuit for testing? Yes No
 If no, explain.

Test Description

HYDROSTATIC: Hydrostatic tests shall be made at not less than 200 psi (13.6 bar) for two hours or 50 psi (3.4 bar) above static pressure in excess of 150 psi (10.2 bar) for two hours. Differential dry pipe valve clappers shall be left open during test to prevent damage. All aboveground piping leakage shall be stopped.

FLUSHING: Flow the required rate until water is clear as indicated by no collection of foreign material in burlap bags at outlets such as hydrants and blow-offs. Flush at flows not less than 400 gpm (1514 L/min) for 4-in. (102-mm) pipe, 600 gpm (2271 L/min) for 5-in. (127-mm) pipe, 750 gpm (2839 L/min) for 6-in. (152-mm) pipe, 1000 gpm (3785 L/min) for 8-in. (203-mm) pipe, 1500 gpm (5678 L/min) for 10-in. (254-mm) pipe and 2000 gpm (7570 L/min) for 12-in. (305-mm) pipe. When supply cannot produce stipulated flow rates, obtain maximum available.

PNEUMATIC: Establish 40 psi (2.7 bar) air pressure and measure drop, which shall not exceed 11/2 psi (0.1 bar) in 24 hours. Test pressure tanks at normal water level and air pressure and measure air pressure drop, which shall not exceed 11/2 psi (0.1 bar) in 24 hours.

*Measured from the time the inspector's test pipe is opened.

Contractor's Material and Test Certificate for Low Expansion Foam Systems

Tests

All piping hydrostatically tested at _____ psi (bar) for _____ hrs.
 Dry piping pneumatically tested? Yes No
 Equipment operates properly? Yes No
 If no, state reason.

Drain test—Reading of gauge located near water supply test pipe: Static pressure: _____ psi (bar)
 Drain test—Residual pressure with valve in test pipe open wide: _____ psi (bar)

Underground mains and lead-in connections to system risers flushed before connections made to sprinkler piping Verified by copy of the U Form No. 85B Yes No Other
 Flushed by installer of underground sprinkler piping Yes No Other
 If other, explain. _____

Blank Testing Gaskets

Number used _____ Locations _____ Number removed _____

Welding

Welded piping? Yes No
 If yes,
 Do you certify as the sprinkler contractor that welding procedures comply with the requirements of at least AWS D10.9, Level AR-3? Yes No
 Do you certify that the welding was performed by welders qualified in compliance with the requirements of at least AWS D10.9, Level AR-3? Yes No
 Do you certify that welding was carried out in compliance with a documented quality control procedure to insure that all discs are retrieved, that openings in piping are smooth, that slag and other welding residue are removed, and that the internal diameters of piping are not penetrated? Yes No

Hydraulic Data Nameplate

Nameplate provided? Yes No
 If no, explain.

Remarks

Date left in service with all control valves open: _____

Sprinkler Contractor: _____

Signatures of Test Witnesses

For property owner (signed) _____ Title _____ Date _____

For sprinkler contractor (signed) _____ Title _____ Date _____

11-39 Log #17
(A.3.3.27)

Final Action: Accept

Submitter: Eldon D. Jackson, The Viking Corporation

Recommendation: Revise text as follows:

The foam trough shown schematically in Figure A.3.3.27(b) A.3.3.5.2 (a) consists of section of steel formed into a chute that is securely attached to the inside tank wall so that it forms a descending spiral from the top of the tank to within 1.2m (4 ft) of the bottom (see figure 3.3.27(e) 3.3.5.2 (b)

Substantiation: Move this paragraph to A.3.3.5.2 to place in proper location of text body. This subject is not related to the section currently located.

Committee Meeting Action: Accept

Number Eligible to Vote: 27

Ballot Results: Affirmative: 24

Ballot Not Returned: 3 LaVergne, E., Santerre, G., Williams, M.

11-40 Log #10

Final Action: Accept in Principle

(Figure A.3.3.27(b))

Submitter: Eldon D. Jackson, The Viking Corporation

Recommendation: Revise text as follows:

3.3.5.2 *, Figure A.3.3.27(b) Figure A.3.3.5.2—Foam Troughs along side of tank wall [see figure 3.3.5.2].

These outlets are to extinguish fire with minimum of foam producing materials. It should be noted that the Type I devices become Type II devices if they suffer mechanical damage. All type I devices are considered obsolete due to all currently manufactured foams being suitable for use with Type II devices [see figure A.5.2.5.2.1.]

Substantiation: Current Figure A.3.3.27(b) is incorrect as 3.3.27 is for around the pump proportioner. The text from previous edition was left out to describe a Type I Discharge device. It could be considered to delete Type I device from the body of this standard as it is no longer applied.

Committee Meeting Action: Accept in Principle

Committee Statement: See Committee Action and Statement on Proposal

11-25 (Log #16).

Number Eligible to Vote: 27

Ballot Results: Affirmative: 24

Ballot Not Returned: 3 LaVergne, E., Santerre, G., Williams, M.

11-41 Log #CP22

Final Action: Accept

(A.4.2.1.1)

Submitter: Technical Committee on Foam,

Recommendation: Add new Annex Section to read as follows:

4.2.1.1* Quality.

A.4.2.1.1 Recycled water, processed water or, grey water can be utilized for foam production, when used, a competent evaluation for the suitability of the water quality should be conducted.

Substantiation: Guidance on the use of recycled water is needed.

Committee Meeting Action: Accept

Number Eligible to Vote: 27

Ballot Results: Affirmative: 24

Ballot Not Returned: 3 LaVergne, E., Santerre, G., Williams, M.

11-42 Log #5

Final Action: Accept

(Figure A.5.3.5.2(a) and Figure A.5.3.6)

Submitter: Bhana D. Mistry, TIW Steel Platework

Recommendation: Revise text as follows:

Revise Fig. A.5.3.5.2(a) and Fig. A.5.3.6 to show Foam Dam thickness 10 gauge (0.134") from 3/16" to comply with 5.3.5.4.

(See Figure A.5.3.5.2(a) on page 19.)

(See Figure A.5.3.6 on page 20.)

Substantiation: Fig. A.5.3.5.2(a) and Fig. A.5.3.6 with 3/16" foam dam is in conflict with 5.3.5.4.

Committee Meeting Action: Accept

Number Eligible to Vote: 27

Ballot Results: Affirmative: 24

Ballot Not Returned: 3 LaVergne, E., Santerre, G., Williams, M.

11-43 Log #23
(G.4.3.1)

Final Action: Accept

Submitter: Klaus Wahle, U.S. Coast Guard (G-MSE-4)

Recommendation: Revise text as follows:

G.4.3.1 Method 1. Fifteen minutes after completion of the foam application, an opening 3870 mm^2 (6 in.^2) $23,220\text{ mm}^2$ (36 in.^2) should be made in the foam blanket approximately 0.6 m (2 ft.) from the side of the pan. The exposed fuel should be reignited with a torch and permitted to burn for 5 minutes. After the 5-minute burning period, the area involved in flames should be determined.

Substantiation: This corrects the size of the area to be opened in the foam blanket for the burnback test. The Coast Guard test which forms the basis of this requirement called for an area 6 inches square (i.e. a square of 6 inches by 6 inches for an area of 36 square inches) to be opened. Apparently, during the standard editing process the awkward wording of "6 inches square" was turned into "6 square inches" with the unintended result of changing this test and making it impractical to carry out.

Committee Meeting Action: Accept

Number Eligible to Vote: 27

Ballot Results: Affirmative: 24

Ballot Not Returned: 3 LaVergne, E., Santerre, G., Williams, M.

11-44 Log #22

Final Action: Accept

(G.5.3.1)

Submitter: Klaus Wahle, U.S. Coast Guard (G-MSE-4)

Recommendation: Revise text as follows:

G.5.3.1 Method 1. The foam blanket should prevent the spread of fire beyond an area approximately $42,902\text{ mm}^2$ (20 in.^2) 0.25 m^2 (2.7 ft.^2)

Substantiation: Consistent with the proposal for G.4.3.1, this corrects the size of the maximum permissible area to which fire may spread during the burnback test. The Coast Guard test which forms the basis of this requirement called for a maximum area 20 inches square (i.e. a square of 20 inches by 20 inches for an area of 400 square inches) to be permitted. Apparently, during the standard editing process the awkward wording of "20 inches square" was turned into "20 square inches" with the result of making the test more severe than intended.

Committee Meeting Action: Accept

Number Eligible to Vote: 27

Ballot Results: Affirmative: 24

Ballot Not Returned: 3 LaVergne, E., Santerre, G., Williams, M.

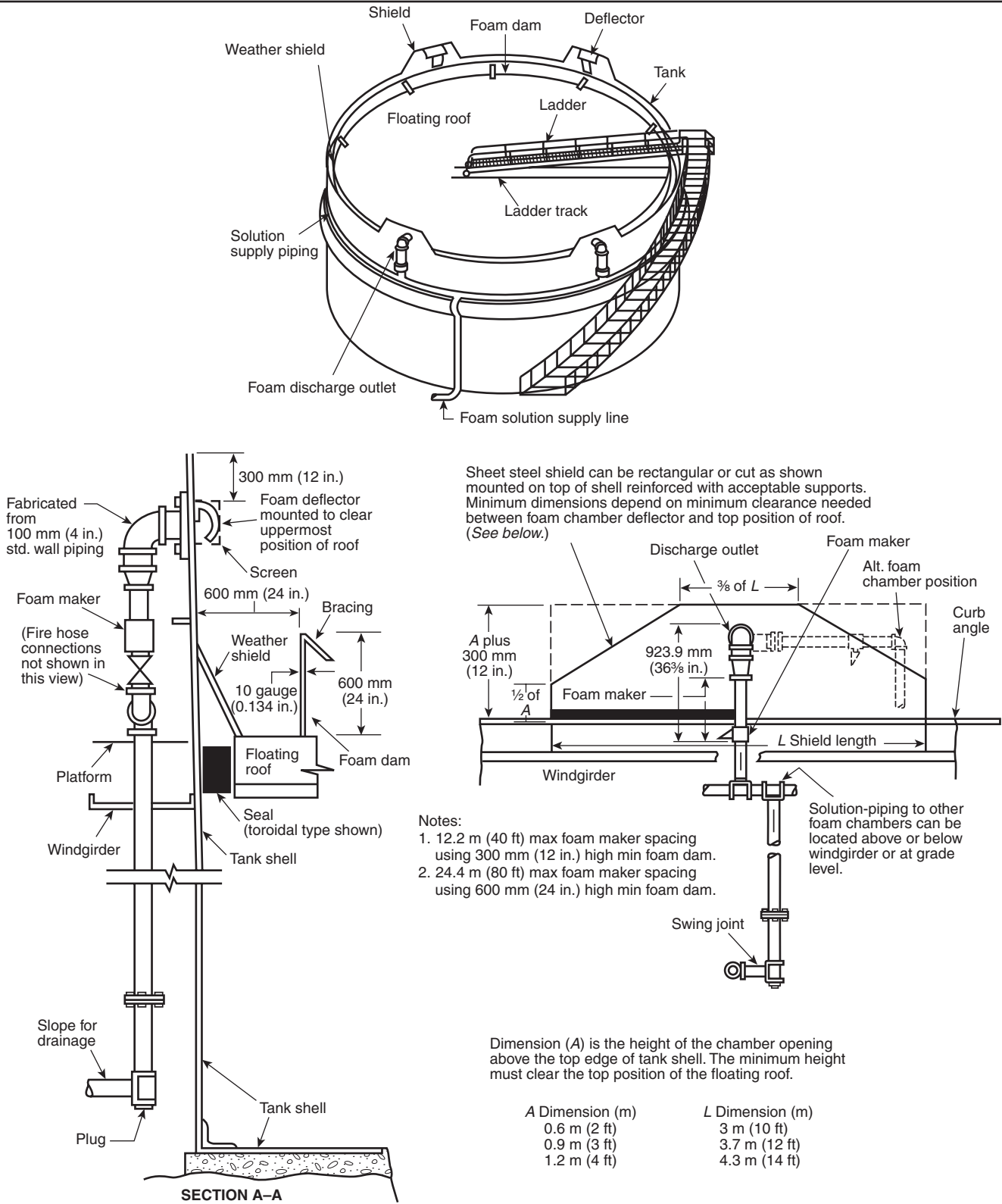

Figure A.5.3.5.2(a) Typical Foam Splash Board for Discharge Devices Mounted Above the Top of the Shell.

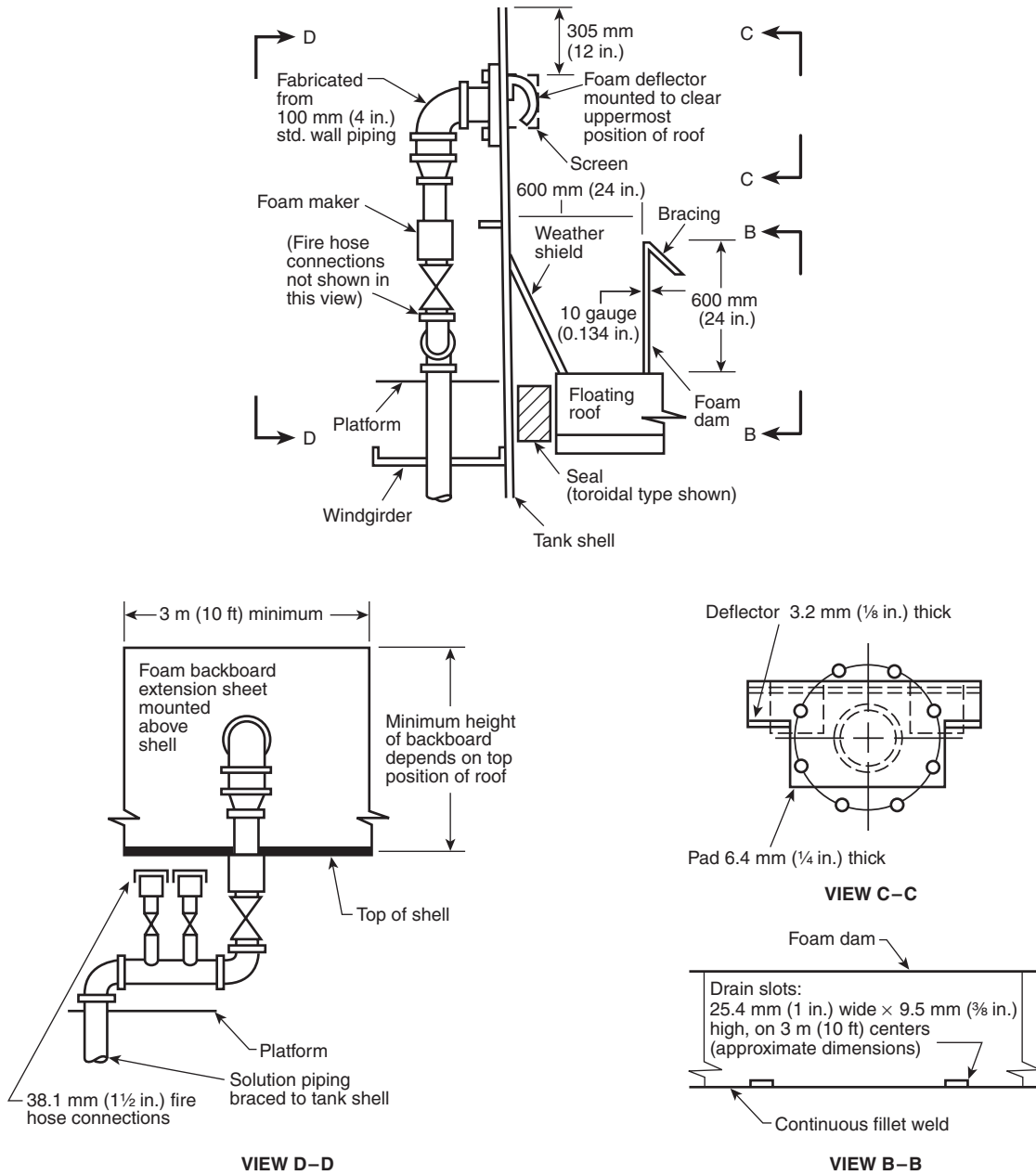

Figure A.5.3.5.2(a) Typical Foam Splash Board for Discharge Devices Mounted Above the Top of the Shell.